

**LAMM**

Conference







Conference Collection

Contents



## Qualità e innovazione Made in Italy

LAMM dal 1959 produce e installa in tutto il mondo sistemi di sedute per sale conferenza, auditorium, università, cinema, teatri e spazi pubblici.

La capacità progettuale, l'ingegnerizzazione e l'organizzazione produttiva permettono all'azienda di rispondere con flessibilità alle esigenze di architetti e committenti, offrendo una vasta gamma di prodotti di serie e soluzioni parzialmente o interamente custom.

L'intero processo, dalla progettazione alla produzione, è realizzato in Italia. L'innovazione abbinata alla qualità artigianale dei prodotti, la cura di ogni dettaglio e la creatività sono valori che negli anni sono stati riconosciuti con numerosi premi internazionali.

L'impegno di LAMM si concretizza anche nell'attenzione che l'azienda rivolge all'ambiente con processi produttivi eco compatibili e sostenibili. La qualità LAMM è attestata dalla conformità alle più importanti certificazioni nazionali e internazionali di prodotto, di processo e di rispetto ambientale.



## Made in Italy quality and innovation

Since 1959, LAMM has been producing and installing seating systems for conference rooms, auditoriums, universities, cinemas, theatres and community facilities throughout the world.

Its design capacity, engineering and production organisation allow the company to be flexible in meeting the needs of architects and clients, offering an extensive range of standard products and partially or entirely bespoke solutions.

The entire process, from design to production, is carried out in Italy. Innovation fused with artisan quality products, attention to detail and creativity are the values that have led to numerous international awards over the years.

LAMM's commitment is also expressed through the company's environmental awareness, demonstrated by its eco-friendly and sustainable production processes. LAMM quality is confirmed by its compliance with the most important national and international certification for products, processes and environmental protection.







## Evoluzione

Il nuovo logo aziendale e il nuovo show-room esprimono con eloquenza il profondo processo di evoluzione avviato da LAMM all'insegna dell'innovazione delle linee produttive, delle politiche di qualità, dello sviluppo di prodotti capaci di coniugare design esclusivo ed elevato contenuto tecnico, essenze, dei tessuti, dei rivestimenti e dei cicli di verniciatura.

## Evolution

The new company logo and show-room eloquently convey the thorough evolution process initiated by LAMM, focused on the innovation of its product lines, quality policies, the development of products able to merge exclusive designs with high technical content, as well as the introduction of new finishes for woods, fabrics, upholstery and painting cycles.







## Tradizione

La profonda conoscenza maturata in oltre 60 anni di attività nei processi produttivi e di mercato, consente a LAMM di rispondere in maniera esaustiva alle complesse variabili del progetto contemporaneo delle sedute polifunzionali per ambienti pubblici.

## Tradition

The extensive experience LAMM has built up in over 60 years of production and market activities enables the company to respond comprehensively to the complex contemporary design variables of multifunctional seating for public facilities.



## Innovazione

Da sempre l'obiettivo di LAMM non è fornire semplici prodotti, ma soluzioni evolute e innovative, attraverso un processo continuo di ricerca sull'uso dei materiali, l'ergonomia e lo sviluppo di tecnologie esclusive, coniugando prestazioni, comfort e design.

## Innovation

From the beginning, LAMM's objective has been to supply not simple products but rather advanced, innovative solutions, by continuous research on the use of materials, ergonomics and developing exclusive technology, to combine performance, comfort and design.



## Design

Grazie alla collaborazione con importanti designer, dare la miglior forma alle idee è parte fondante della cultura produttiva di LAMM. Lo testimoniano i numerosi premi e riconoscimenti internazionali conseguiti nel campo dell'industrial design.

## Design

Through partnerships with leading designers, giving ideas the best shape is an essential part of LAMM's production culture. The many international prizes and recognitions LAMM has been awarded for industrial design demonstrate this.





### Made in Italy

I prodotti LAMM sono interamente realizzati in Italia. La sensibilità nella selezione delle materie prime, la cura dei dettagli, la passione che lega saperi artigianali e hi-tech, collocano la produzione nell'alta tradizione del Made in Italy.

### Made in Italy

LAMM products are entirely made in Italy. Awareness in the selection of raw materials, attention to detail, and a passion uniting artisan knowledge with hi-tech, position LAMM production in the finest "Made in Italy" tradition.







### Ambiente

L'impegno di LAMM per le politiche ambientali va aldilà del semplice rispetto delle leggi in materia. Ricerca di processi virtuosi, riduzione degli sprechi, elevata efficienza energetica, basso impatto ambientale e attenta selezione dei materiali sono solo alcuni degli impegni di cui l'azienda si fa carico in tema di Green Economy.

### Environment

LAMM's commitment to environmental policies goes beyond simple compliance with the relevant laws. Seeking virtuous processes, waste reduction, energy efficiency, low environmental impact and careful material selection are just some of the commitments the company takes on in the Green Economy area.

### Crediti LEED®

LAMM rientra ufficialmente nella "green community" GREENiTOP®, cioè in quella ristretta cerchia di aziende virtuose che hanno a cuore le performance ambientali dei propri prodotti nel contesto di edifici sostenibili certificati LEED®. I prodotti LAMM contribuiscono infatti in maniera determinante al raggiungimento dei più elevati punteggi in chiave di sostenibilità edilizia secondo lo standard di valutazione LEED®

### LEED® Credits

LAMM is officially part of the GREENiTOP® 'green community', i.e. a small group of exemplary companies that care about the environmental performance of their products in the context of LEED®-certified green buildings. LAMM products play a decisive role in helping those who adopt them to achieve the highest building-sustainability scores based on LEED® assessment standards.





## Ricerca e sostenibilità

LAMM svolge attività di ricerca e sviluppo anche nel campo della sostenibilità, partecipando a iniziative dedicate al design del riuso, come UMUL (Use More Use Less). L'obiettivo è sperimentare soluzioni innovative volte al reimpiego di materiali e componenti dismessi, così come di sistemi di produzione alternativi, capaci di coniugare risultati di elevata qualità estetica con contenuti ecologici e di sostenibilità.

## Research and sustainability

LAMM also conducts research and development in the sustainability field, by participating in reuse design initiatives such as UMUL (Use More Use Less). The objective is to test innovative solutions for reusing disused materials and components, as well as alternative production systems that combine highly aesthetic products with ecological and sustainable content.



## Materie prime

I materiali vengono selezionati al fine di limitarne l'impatto ambientale durante le fasi di produzione, lavorazione, riciclaggio e smaltimento. Il legname è certificato FSC®, a garanzia della provenienza da foreste gestite in maniera responsabile. I pannelli in truciolare, prodotti con materiale riciclato, rientrano nella Classe E1 per le emissioni di formaldeide. L'alluminio fa largo impiego di materia prima riciclata e a sua volta viene totalmente riutilizzato a fine ciclo di vita.

## Raw materials

Materials are selected to limit their environmental impact during production, processing, recycling and disposal. Timber is FSC® certified, guaranteeing it was sourced from responsibly managed forests. Chipboard panels made of recycled wood are in Class E1 for formaldehyde emissions. Aluminium has a high recycled raw material content and, in turn, can be totally reused at the end of its lifecycle.







## Certificazioni

LAMM è certificata secondo lo standard UNI EN ISO 14001. Procedura non obbligatoria che testimonia la volontà di stabilire e attuare un sistema di gestione ambientale, anche attraverso il controllo dell'impatto delle attività aziendali, ricercandone sistematicamente il miglioramento. La certificazione FSC® del tipo Catena di Custodia (Chain of Custody) garantisce la rintracciabilità dei materiali provenienti da foreste gestite in maniera responsabile, dal produttore al cliente finale.

## Certifications

LAMM is certified in accordance with the UNI EN ISO 14001 standard. This optional procedure shows the company's will to set up and implement an environmental management system, including through the monitoring of its activities, and systematically seek improvement. The FSC® certification of type Chain of Custody guarantees the traceability of the materials coming from responsibly managed forests, from the producer to the final customer.



## Riduzione degli sprechi

Minimizzare lo spreco di materie prime è per LAMM un impegno concreto. Un obiettivo perseguito attraverso numerose sperimentazioni orientate a ottimizzare l'uso delle risorse. Tra gli esempi, la seduta-prototipo Wotu, dove il ciclo di produzione, alimentato al 90% da energia elettrica ricavata termovalorizzando i cascami di legno della produzione, è stato sviluppato per ottenere il prodotto interamente dallo stesso albero.



## Waste reduction

Minimising raw material waste is a concrete commitment of LAMM and a goal it pursues with numerous tests aimed at optimising the use of resources. Examples include the prototype-chair Wotu, whose production cycle - 90% powered with electricity obtained by waste-to-energy incineration of wood production waste – was developed to obtain the entire product from the same tree.



## Soluzioni e servizi

LAMM è in grado di supportare il cliente in ogni fase, dalla progettazione alla produzione, dallo studio di fattibilità al montaggio, individuando, di volta in volta, la soluzione più idonea a soddisfare le specifiche richieste, compresa la possibilità di personalizzare la fornitura partendo dallo sviluppo di un concept inedito o dalla rielaborazione di prodotti di serie. Tra i servizi offerti dall'azienda si evidenziano: la preventivazione accompagnata dall'elaborazione del layout; la precisa e puntuale produzione, garantendo l'elevata qualità dei prodotti; la logistica delle consegne; l'allestimento, la posa in opera e il collaudo dell'intervento; la prestazione di post-vendita. LAMM inoltre è in grado di fornire progetti "chiavi in mano", assumendo il ruolo di general contractor.

## Solutions and services

LAMM can support customers in all phases, from design to production, feasibility study and installation included, finding every time the best solution for specific requests. Moreover, the company offers the possibility of customising the supply by developing a brand-new concept or by redesigning series products.

An estimate with its specific layout, the prompt and precise high-quality production, the logistic management of deliveries, the product installation and testing and the after-sales assistance are only some of the services provided. LAMM can also conceive turnkey projects by taking on the role of general contractor.

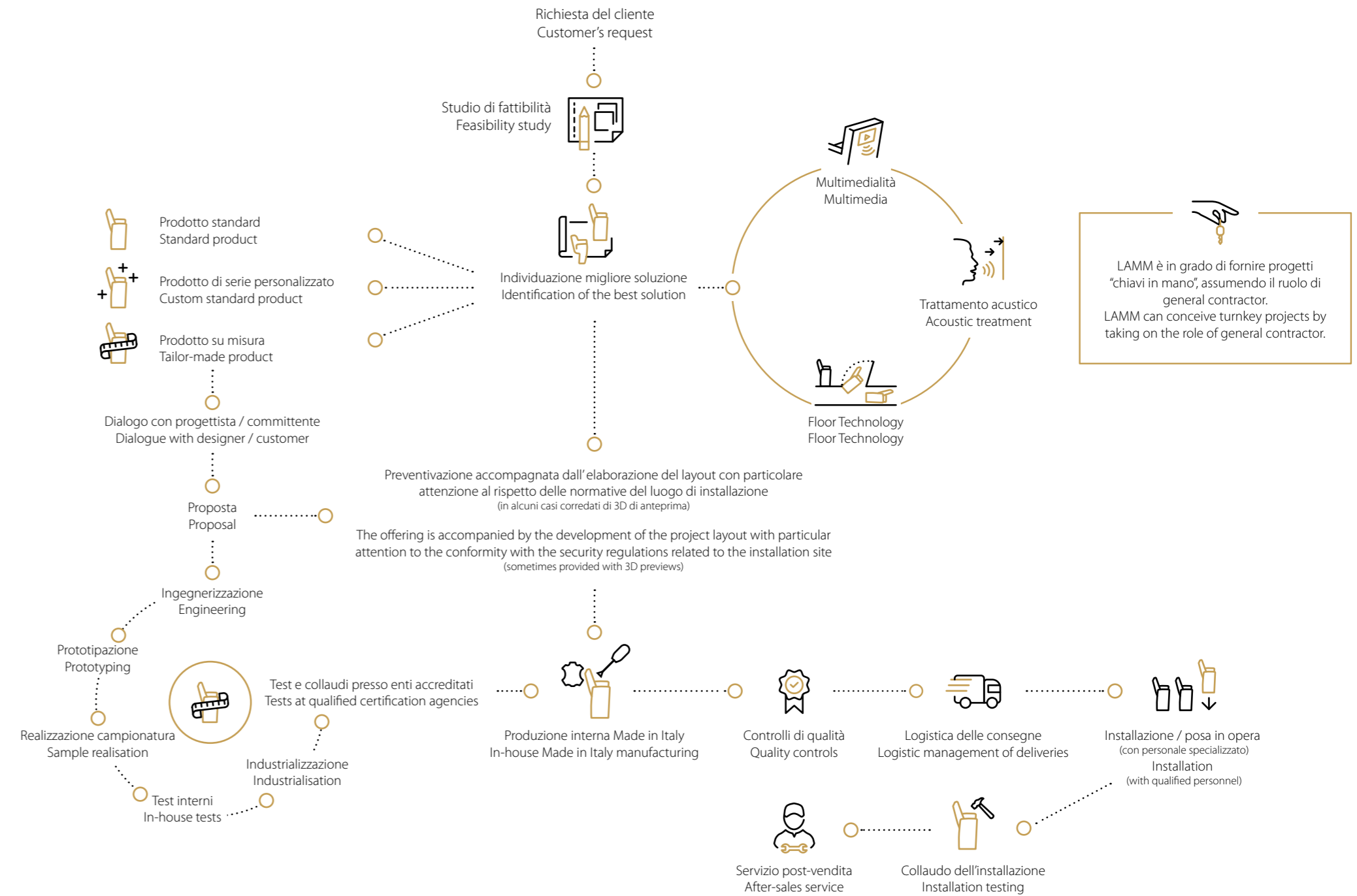
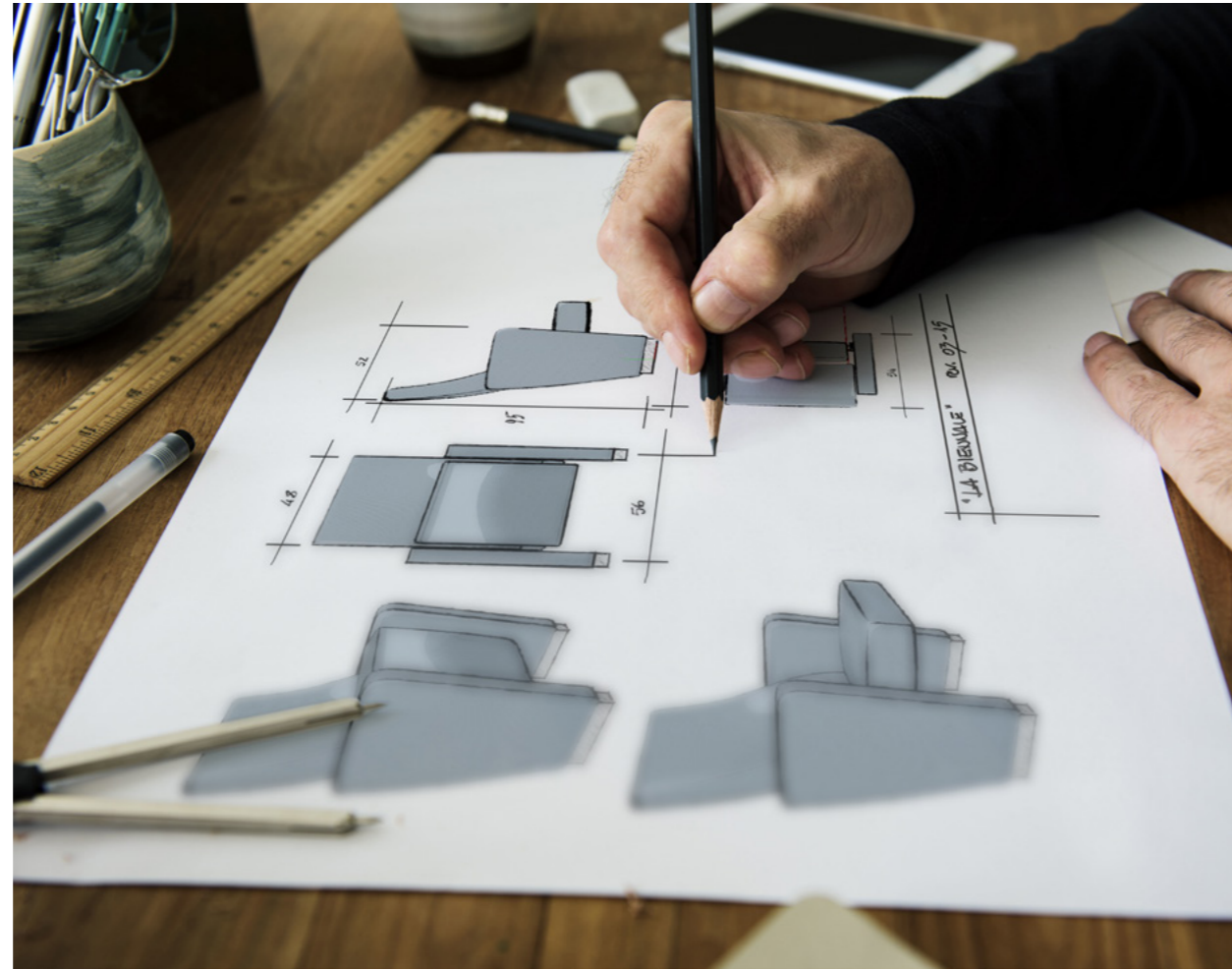



## Personalizzazione

Il processo produttivo messo a punto da LAMM consente di beneficiare ai più alti livelli della elevata costanza qualitativa dei cicli a sofisticata tecnologia unita al valore aggiunto della sensibilità e della maestria artigianale del Made in Italy. Grazie a questo connubio e alla capacità di interpretare le esigenze dell'interior design contemporaneo, LAMM è in grado di assecondare gli obiettivi di flessibilità e personalizzazione espressi dalla singolarità di ogni intervento sia modificando e adattando i propri sistemi di seduta e di banchi studio sia sviluppando soluzioni originali e inedite.

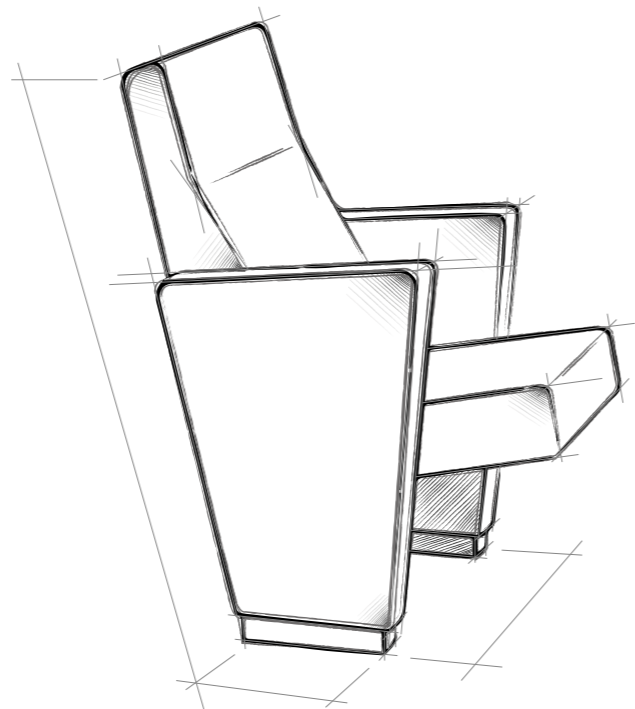

Custom armchair for  
La Biennale di Venezia, New Sala Darsena - Venice, Italy

## Customisation

The production process developed by LAMM provides superior benefits, such as consistent high quality in production cycles and sophisticated technology, combined with the added value that stems from the innate understanding and craftsmanship that imbues Made in Italy excellence. Thanks to this combination and its ability to interpret the needs of contemporary interior design, LAMM can meet the flexibility and customisation objectives expressed in the uniqueness of each project by modifying and adapting its seating systems and study benches and developing original, innovative solutions.





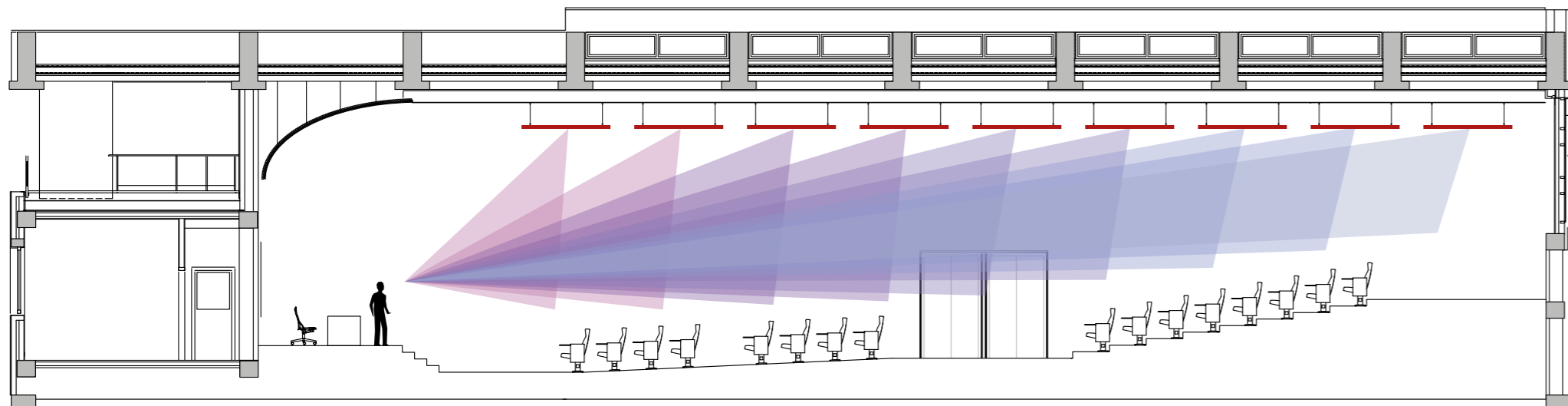

## Acustica

Il comfort acustico è elemento qualitativo essenziale per il buon funzionamento di un'aula, una sala conferenze, un luogo di spettacolo. Per raggiungere ai massimi livelli questo risultato LAMM è in grado di fornire ad architetti e progettisti un servizio dedicato, articolato su due specifici campi d'azione: la specializzazione dei suoi sistemi di sedute, peraltro già concepiti per fornire adeguate prestazioni in questo senso e, non secondariamente, l'allestimento complessivo degli ambienti finalizzato al conseguimento dei più elevati obiettivi di comfort avvalendosi del know-how e dell'esperienza messi a disposizione dalla Caruso Acoustic®, divisione altamente qualificata nella produzione di pannelli fonoassorbenti.

## Acoustics

Acoustic comfort is a key element for the proper functioning of a classroom, conference room or performance space. In order to achieve the highest levels of acoustic comfort, LAMM can provide architects and designers with a dedicated service divided into two specific action areas: the specialisation of its seating systems, which have already been designed to offer sufficient performance in this area and, last but not least, the total space outfitting conceived to offer the highest levels of comfort, making use of the expertise provided by Caruso Acoustic®, division highly specialised in the production of sound-absorbing panels.



## Multimedialità

Banchi studio, poltrone e sistemi di sedute sono sviluppati per favorire la massima integrazione e sinergia con tutti i sistemi di multimedialità che oggi concorrono alle attività educative e conferenze. Il concept messo a punto da LAMM è di tipo inclusivo e a elevata flessibilità, con cablaggi totalmente integrati e protetti, flessibili, adattabili e personalizzabili alle più diverse esigenze. Gli stessi dispositivi di interconnessione risultano perfettamente coerenti col design d'insieme, oltre che di facile e intuitivo impiego.

## Multimedia

Study benches, armchairs and seating systems are designed to promote maximum integration and synergy with all multimedia systems used nowadays in educational and conference activities. The concept developed by LAMM is inclusive and highly flexible, featuring totally integrated, protected and flexible wiring that can be adapted and customised to a wide range of needs. The interconnection devices go perfectly with the overall design, and are also easy and intuitive to use.



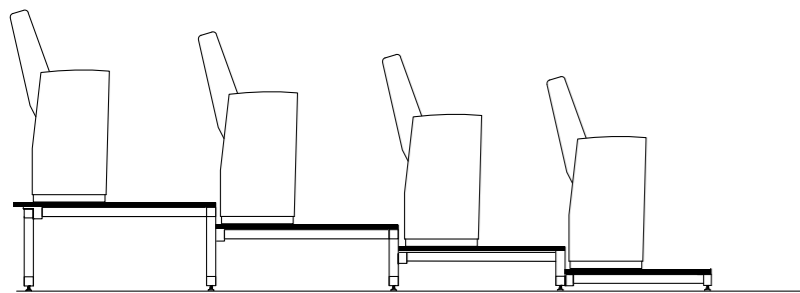

Pedane e tribune fisse  
Fixed tribunes and platforms

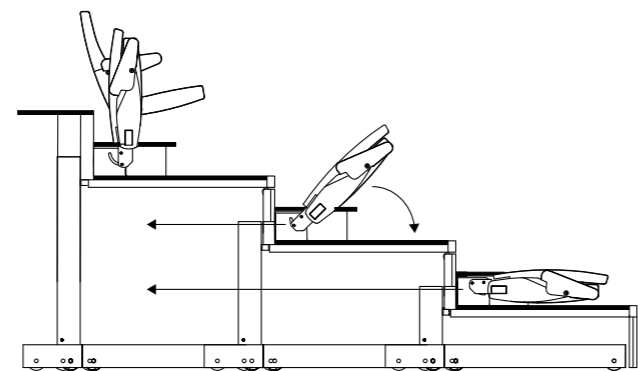

Tribune telescopiche  
Telescopic tribunes

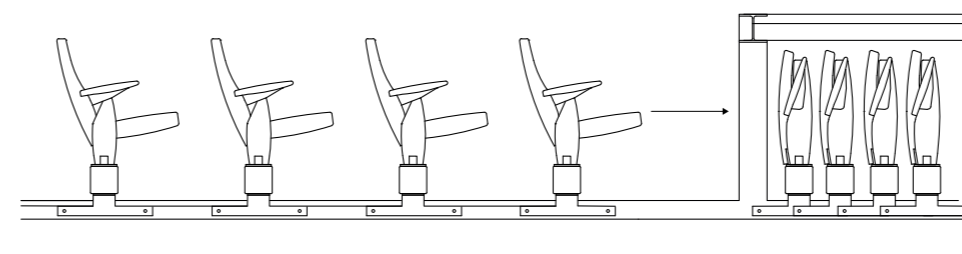
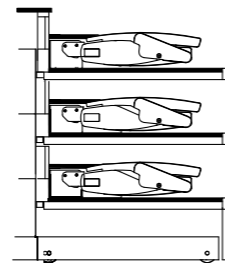

Sistemi a scomparsa su binario  
Sliding seating systems

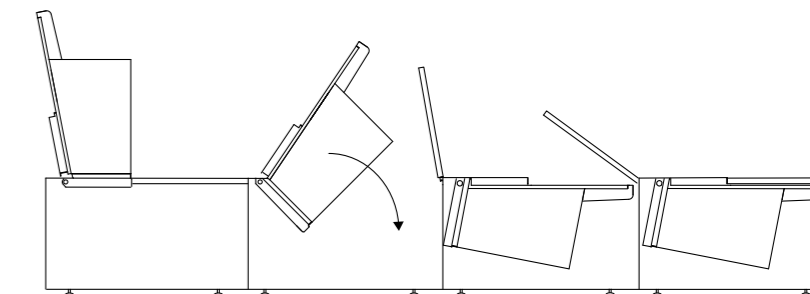

Sistemi a scomparsa  
Hiding seating systems

### Sistemi speciali fissi e a scomparsa

La visione di LAMM legata alla qualità globale nell'allestimento delle aule universitarie e delle sale conferenze e per spettacoli, ha condotto alla messa a punto di una completa serie di sistemi di pedane e tribune fisse, alle quali si aggiunge una articolata offerta di sistemi speciali capaci, attraverso semplici operazioni automatizzate, di trasformare in pochi istanti gli ambienti, rendendoli disponibili ad altre funzioni d'uso. I sistemi comprendono pavimenti volventi (le poltrone ruotano e scompaiono completamente sotto il piano di calpestio), pedane e gradinate telescopiche (le poltrone vengono raccolte e compattate lungo una parete), dispositivi su binario incassato a pavimento (le file di poltrone scorrono e si compattano orizzontalmente sotto il palco o in appositi volumi di contenimento).

### Special fixed and hidden systems

LAMM's vision for a global standard in fittings for university lecture halls, conference rooms and performance spaces led it to design a complete series of fixed tribunes and platforms. These are complemented by a wide range of special systems that can transform the spaces in just a few seconds through simple automated actions and make them available for other uses. These systems include rolling flooring (seats rotate and fully conceal beneath the flooring), tribunes and telescopic terraced steps (seats are collected and compacted along the wall), devices on tracks set into the floor (the rows of seats slide and compact horizontally beneath the stand or in specific storage spaces).



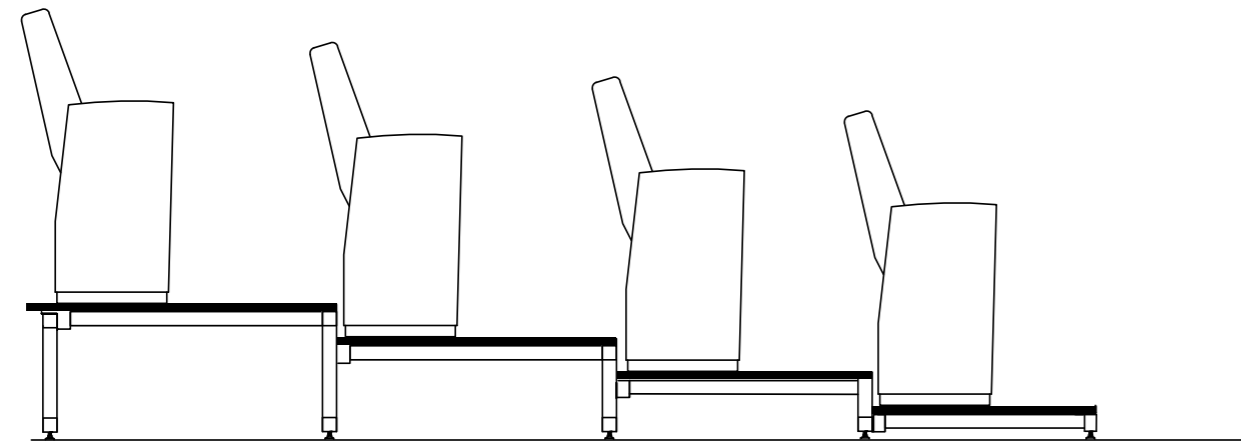

### Pedane e tribune fisse

Sistemi modulari multiuso che consentono di ridefinire uno spazio in brevissimo tempo. Leggere, flessibili e di facile montaggio, pedane e tribune fisse, sono composte da una struttura reticolare metallica e una pavimentazione ispezionabile con finitura superficiale personalizzabile secondo esigenze progettuali. Progettate e realizzate secondo adeguati calcoli strutturali, permettono l'applicazione di accessori come scale, parapetti e scale PMR. Su richiesta possono essere personalizzate per accogliere impianti di climatizzazione e illuminazione segna-gradino. Permettono l'installazione di tutti i prodotti delle collezioni Conference & Education.

### Raised platforms and fixed tribunes

Multi-purpose modular systems, which can transform a space in a short time. Lightweight, flexible and easy to install, raised platforms and fixed tribunes are composed of a metal reticular structure and an inspectionable floor with a surface finish, which can be customised according to project requirements. Designed and realised according to appropriate structural calculations, they allow the installation of accessories such as stairs, railings and PRM stairs. Air conditioning systems and step lighting can be added on request. They allow the installation of all Conference & Education products.







### Sistema a scomparsa

Macchina automatica che permette la movimentazione a scomparsa delle sedute in posizione orizzontale sotto il pavimento. Sistema applicabile alle sedute da conferenza, personalizzabile secondo le esigenze del progetto.

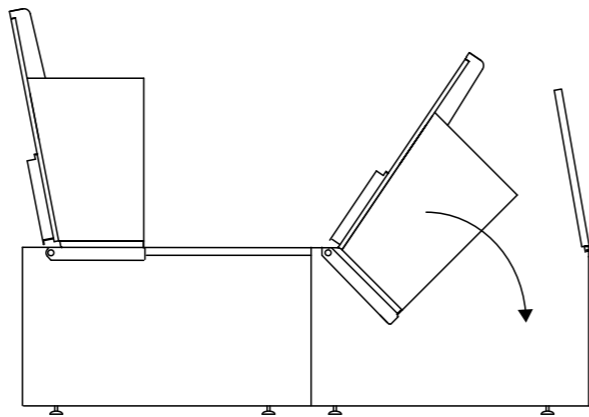

### Hiding seating system

This automatic machine allows the seats to be moved out of sight into a horizontal position under the floor. This system can be used for conference seating and customised according to the needs of the project.

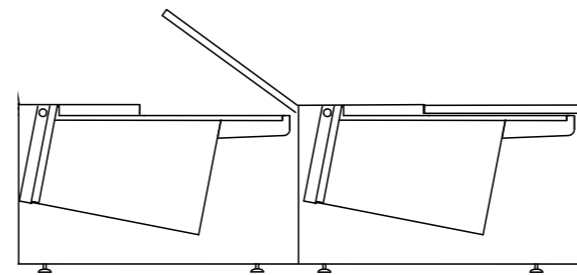



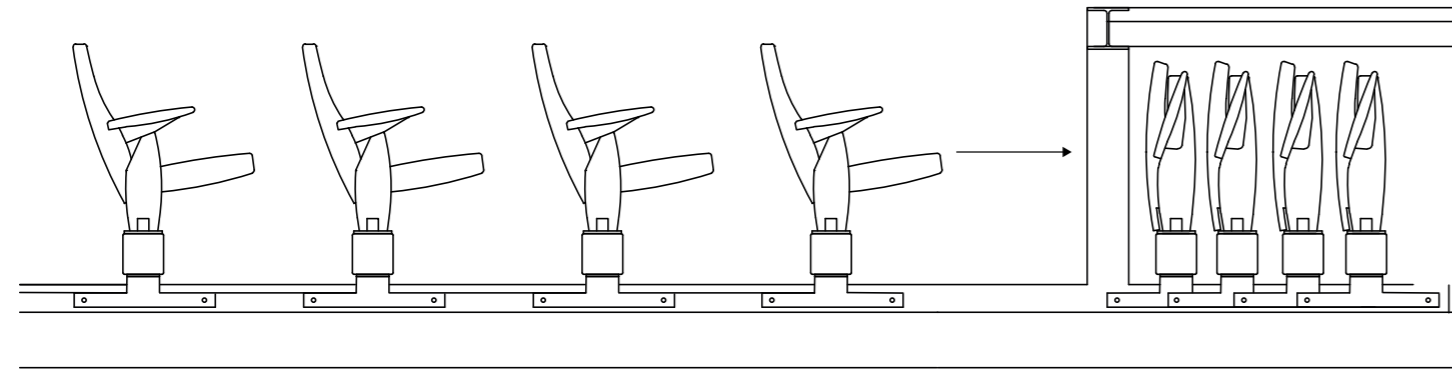

### Sistema a scomparsa su binario

Sistema che permette la movimentazione manuale delle sedute su binari incassati nella pavimentazione permettendo di spostarle e riporle sotto il palco o in appositi locali di stoccaggio al termine dell'utilizzo. Applicabile alla poltrona Futura e personalizzabile secondo le esigenze di progetto.

### Sliding seating system

This system lets you move the seats manually on tracks built into the floor so you can move and store them under the stage or in suitable storage premises after use. It can be used with the Futura armchair and customised according to the project needs.







### Tribune telescopiche

Macchina automatica che permette la movimentazione a scomparsa a parete delle sedute attraverso il sistema telescopico di compattamento. Sistema personalizzabile applicabile sia alle poltrone da conferenza che ai banchi per la didattica (novità assoluta).

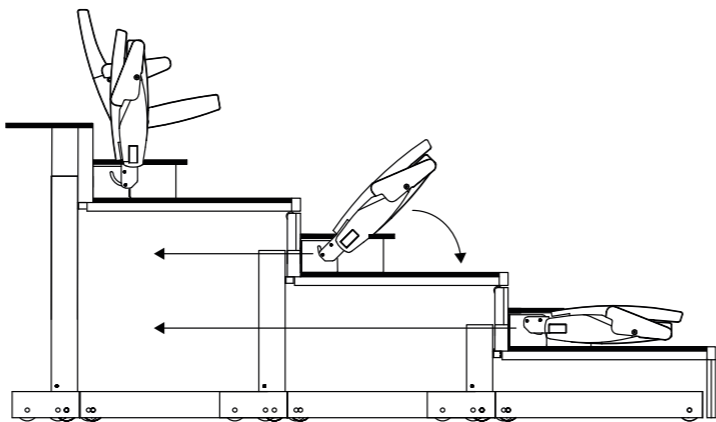

### Telescopic tribune

This automatic machine allows the seats to be moved out of sight into the walls by means of a telescopic compaction system. This customisable system can be used for conference seating or classroom desks (brand new feature).

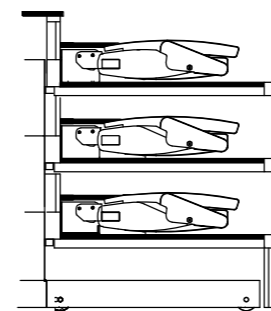





## Conference

### Risposte esclusive per ambienti complessi

Per LAMM il design non è mai un semplice esercizio di stile, ma la capacità di comprendere e tradurre in prodotti iconici le complesse esigenze del mercato.

In primo piano gli ambienti Conference ed Education, dove ha saputo sviluppare sistemi che hanno contribuito all'evoluzione dell'intero settore.

In questo campo LAMM vanta un'esperienza di livello assoluto che spazia dalle poltrone ai banchi didattici, attraverso una vasta proposta di collezioni a catalogo, così come di soluzioni personalizzate.

Un approccio che si traduce in prodotti caratterizzati dalla capacità di unire al raffinato design innovative soluzioni tecnologiche, una esclusiva sensibilità nella scelta e nella lavorazione dei materiali, una elevata attenzione rivolta ai livelli di comfort, ergonomia, flessibilità d'uso, qualità, sicurezza e durabilità.

Il lunghissimo elenco di prestigiose realizzazioni internazionali rendono la migliore testimonianza di questa esperienza.

A completare l'offerta i sistemi dinamici a scomparsa delle poltrone e in assoluta esclusiva dei banchi didattici, per l'organizzazione autoadattativa e polifunzionale degli spazi conferenze. Soluzioni intelligenti, completamente automatizzate, capaci di mutare in pochi attimi la configurazione e la destinazione d'uso delle sale, trasformandole in luoghi pronti ad accogliere funzioni differenti, all'insegna della flessibilità e della razionalizzazione.

### Exclusive solutions for complex spaces

At LAMM, design is never merely a simple stylistic exercise, but rather the ability to recognise and transform complex market needs into iconic products.

Conference and Education spaces are front and centre, it is here that LAMM has been able to create systems that have contributed to the development of the entire sector.

LAMM has a long-standing experience in this field, which ranges from armchairs to study benches and includes a wide selection of catalogue collections, as well as bespoke solutions. This is an approach which results in products distinguished by their capacity to merge innovative technical solutions with stylish designs, innate understanding in selecting and crafting materials and a strong focus on comfort, ergonomics, flexibility of use, quality, safety and durability.

The lengthy list of prestigious international projects is the best testimony to this experience.

The dynamic foldaway seating systems and utterly exclusive study benches round out the offer, providing solutions for auto-adaptive and multifunctional organisation of conference spaces. Intelligent, fully automated solutions that can change the set-up and use of rooms in just a few seconds, transforming them into spaces ready to be used for different purposes, all designed around flexibility and streamlining.



# Genya

Dante Bonuccelli







### Ergonomia e comfort

Schienale dotato di molleggio e dispositivo di supporto lombare, che si assesta con un movimento sincronizzato all'apertura del sedile. Imbottitura a densità differenziata, che assicura un elevato senso di benessere.

### Ergonomics and comfort

The backrest has a lumbar support that is adjusted through a synchronized movement at the opening of the seat. Different densities of padding, to ensure a feeling of great well-being.

### Struttura

Solido e di elevate qualità tecniche, il telaio portante interno, in metallo verniciato, viene fissato direttamente alla pavimentazione, eliminando qualsiasi appoggio a vista. L'installazione può avvenire su piano orizzontale, inclinato o su gradoni, in file diritte o in curva (su progetto).

### Structure

Solid and with high technical qualities, the internal load-bearing frame, made of painted metal, is fixed directly to the flooring, eliminating any visible support. Installation can be on horizontal flooring, sloped flooring or on steps, in straight or curved rows (according to project).





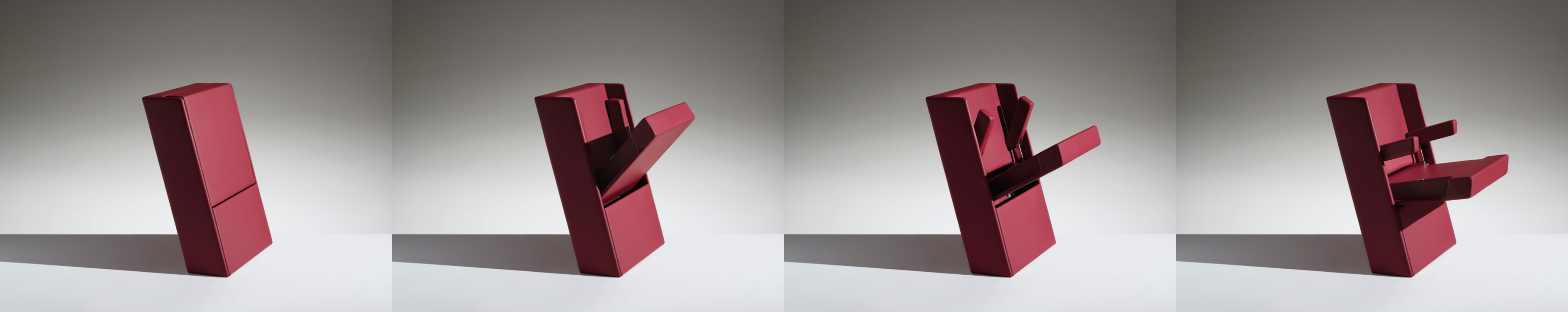

## Design e tecnologia

Poltrona definita da un raffinato design minimalista associato a innovative soluzioni tecnologiche. Nella configurazione chiusa presenta una forma compatta, con tutti i componenti celati nel volume. Sedile e braccioli si aprono con movimento sincronizzato (brevettato) a chiusura ammortizzata.

## Design and technology

Armchair, with an elegant minimalist design associated with innovative technological solutions. When closed it has a compact shape, with all its components contained within the volume. Seat and arms open with a synchronised movement (patented) with cushioned closure.





### Sistema a scomparsa

Installabile con l'innovativo sistema a scomparsa *Floor Technology* che, in breve tempo, nasconde la seduta in posizione orizzontale sotto il pavimento.

### Hidden system

It can be installed with the innovative *Floor Technology* foldaway system that, in a very short time, hides the seat in a horizontal position under the flooring.











Finiture - Finishes



## Dimensioni - Dimensions

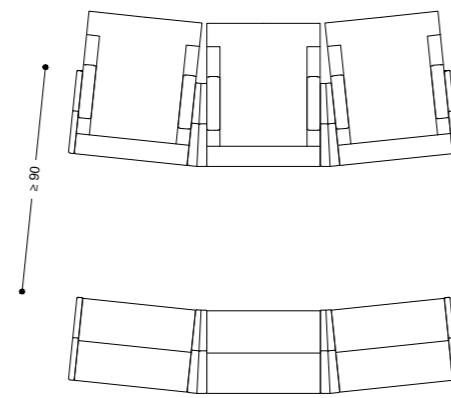
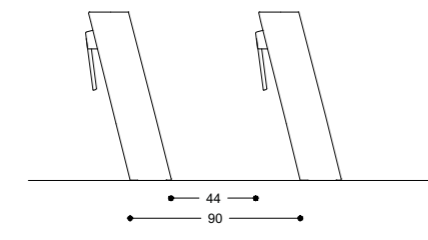
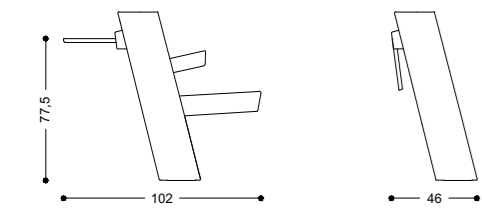
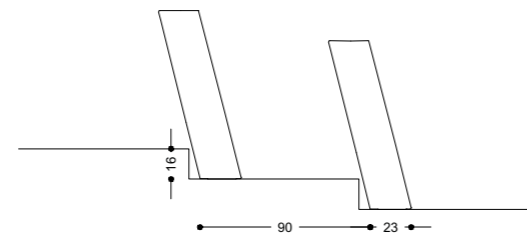
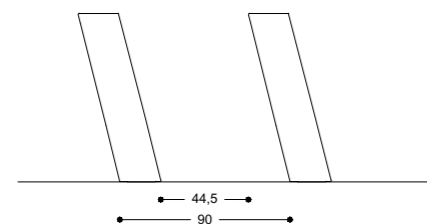
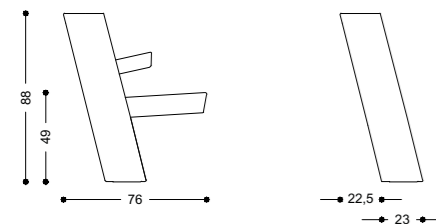
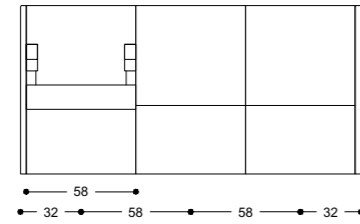
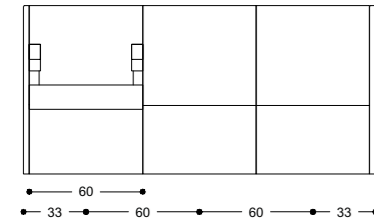

## Accessori - Accessories



Elemento di identificazione fila e numerazione posto  
Row identification and seat numbering element



Predisposizione nella base per dispositivi di aerazione  
Provision in the base for ventilation devices



Retro-schienale in legno verniciato  
Painted wood backrest panel

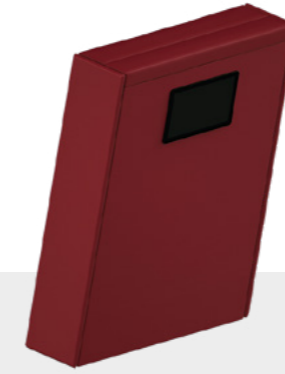

Predisposizione per sistema audio/video integrato nello schienale  
Provision for an integrated monitor/audio system in the backrest



Predisposizione per l'elettrificazione (presa elettrica su richiesta)  
Provision for electric power supply (socket on demand)



Tavolino retro-schienale ribaltabile con movimento anti-panico  
Backrest tip-up table with anti-panic movement



L213







### Design razionale

Poltrona che si qualifica per lo studio dei particolari, il design essenziale, la linearità e la compostezza dei moduli. Aspetti compositivi che la valorizzano sia nella vista frontale che posteriore rendendola adatta a qualsiasi ambiente architettonico.

### Versatilità e attrezzabilità

Fiancata portante inclinata o dritta con struttura metallica interna, completamente imbottita e rivestita oppure in legno; disponibile anche con spessore maggiorato e tavoletta ribaltabile a scomparsa. Retro-schienale accessoriabile con tavolino di servizio.

### Rational design

An armchair that stands out for its attention to details, essential design, linear appearance and the neatness of its units. All aspects of composition that enhance both the front and rear view, making the L213 suitable for any architectural environment.

### Versatility and equipment

Inclined or straight bearing side with internal metal structure, fully padded and covered or made of wood; available with increased thickness and tip-up foldaway writing tablet. The rear backrest can be fitted with a service table.







### **Ergonomia e comfort**

L'inclinazione coordinata di sedile e schienale definisce una condizione di seduta molto confortevole e rilassante, studiata per favorire una permanenza prolungata nel tempo.

### **Sedile e schienale**

Sedile ribaltabile a gravità e schienale con struttura interna in multistrato e imbottitura in schiuma poliuretanic sagomata indeformabile, a combustione ritardata. Retro-schienale in multistrato a vista oppure imbottito e rivestito. Fissaggio a pavimento mediante piede di ancoraggio coperto da un carter metallico verniciato. L'installazione può avvenire su piano orizzontale, inclinato o su gradoni, in file diritte o in curva.

### **Ergonomics and comfort**

Coordinated inclination of seat and backrest makes sitting extremely comfortable and relaxing, designed to foster the time spent on the armchair.

### **Seat and backrest**

Gravity tip-up seat and backrest with a plywood internal structure and padding in non-deformable, fire-retardant, shaped polyurethane foam. Visible plywood or padded and covered rear backrest. Floor fixing by means of an anchoring foot encased in a painted metal collar. Installation on horizontal and sloped flooring or on steps, in straight or curved rows.





### Sistema a scomparsa

Installabile con l'innovativo sistema a scomparsa *Floor Technology* che, in breve tempo, nasconde la seduta in posizione orizzontale sotto il pavimento.

### Hidden system

It can be installed with the innovative *Floor Technology* foldaway system that, in a very short time, hides the seat in a horizontal position under the flooring.

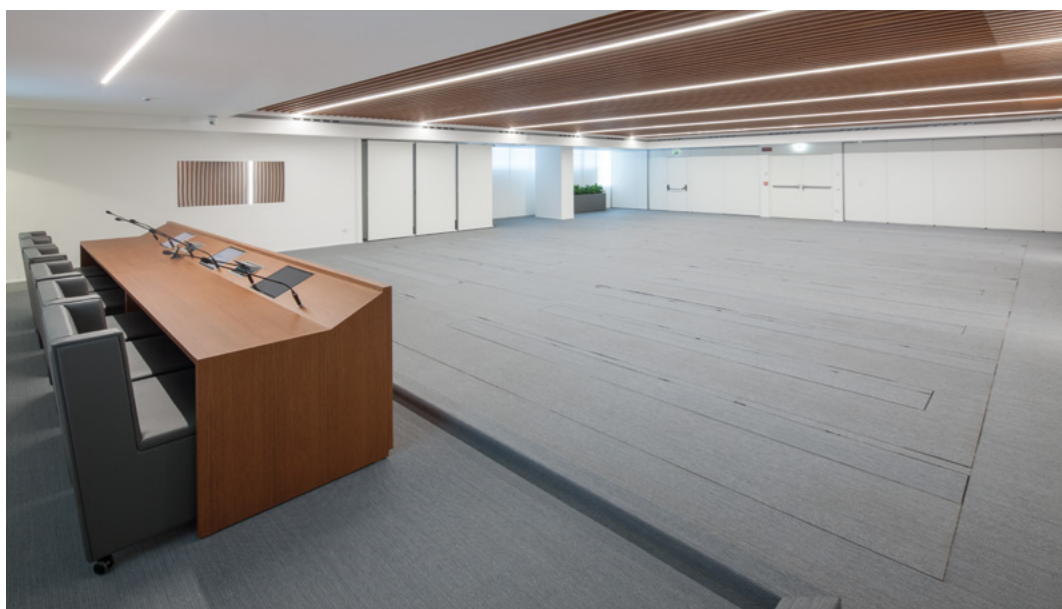









Apple iOS Developer Academy Great Hall - University of Naples Federico II  
Naples, Italy







Finiture - Finishes



## Dimensioni - Dimensions

L213 Fiancata standard inclinata o dritta - L213 with standard side (inclined or straight)

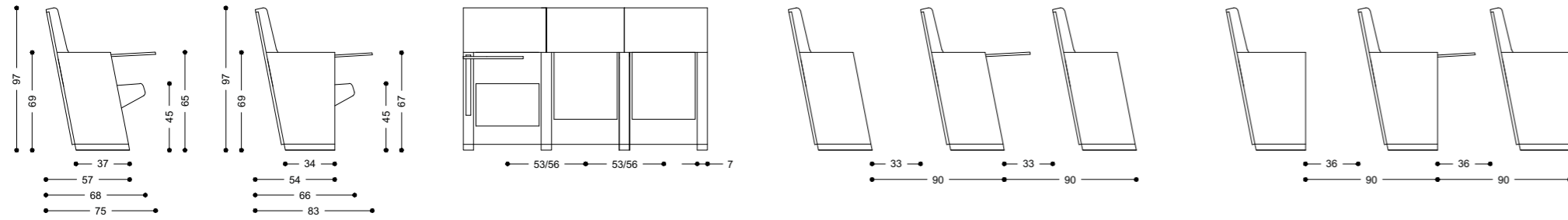

L213 Fiancata standard e maggiorata inclinata o dritta - L213 with standard and increased width side (inclined or straight)

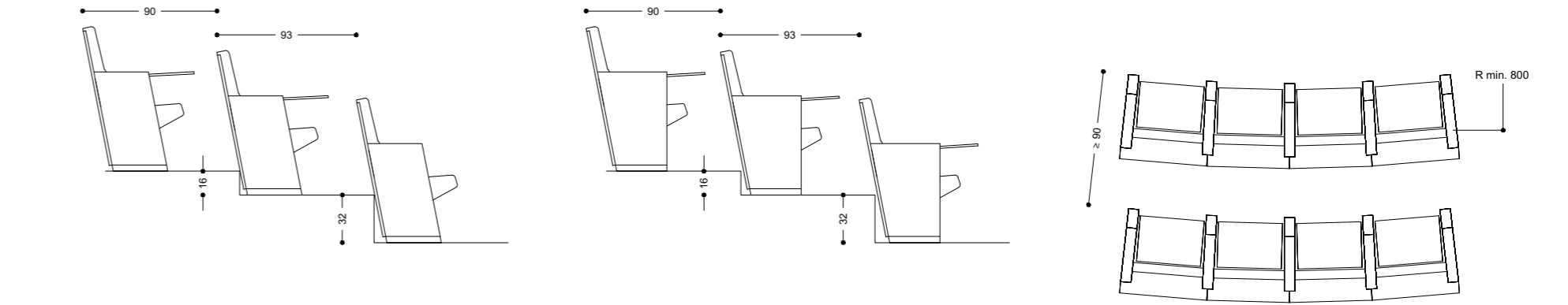

L213 Fiancata maggiorata inclinata o dritta - L213 with increased width side (inclined or straight)

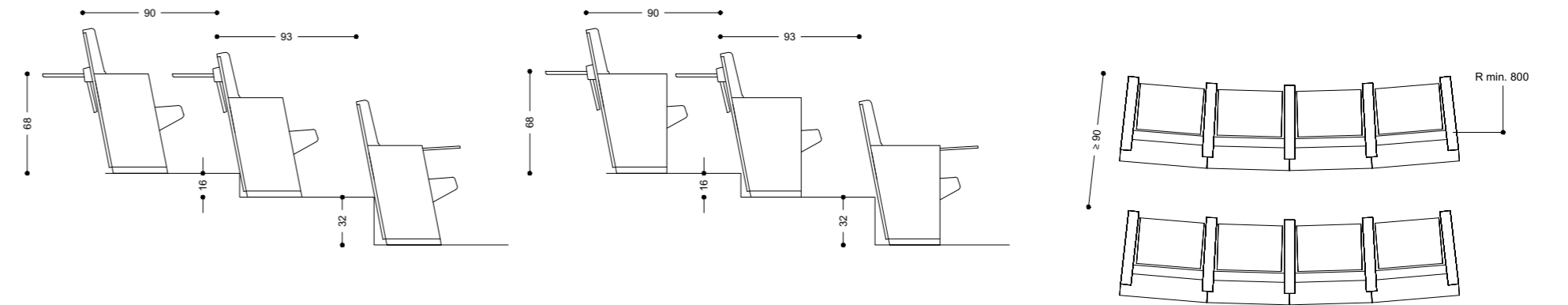
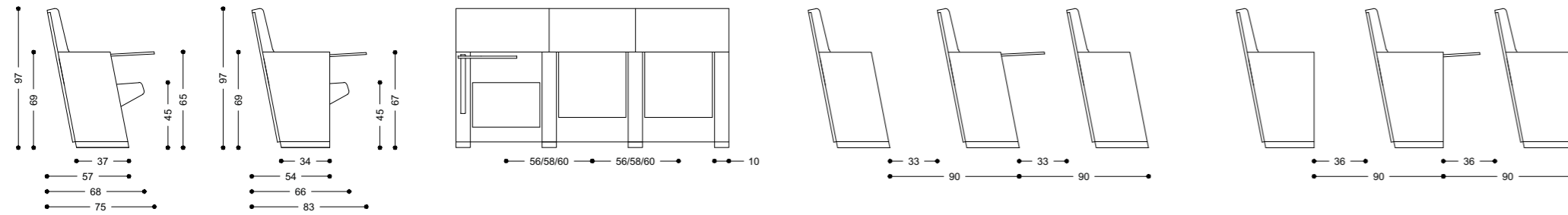



## Accessori - Accessories

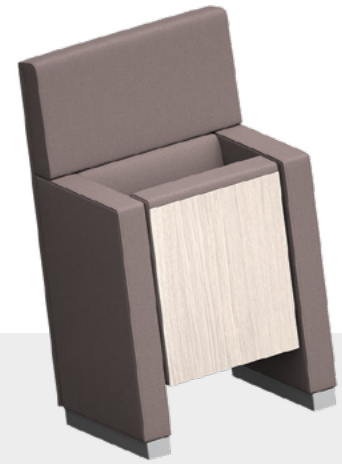

Pannello sotto-sedile in legno verniciato  
Painted wood under-seat panel

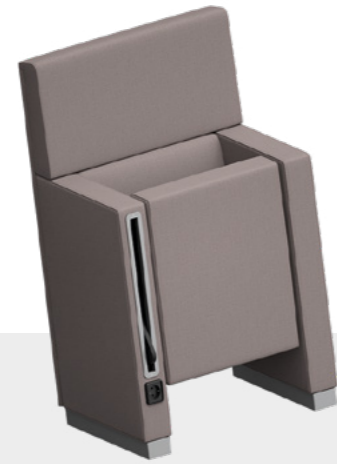

Predisposizione per l'elettrificazione (presa elettrica su richiesta)  
Provision for electric power supply (socket on demand)



Sistema che permette l'amovibilità delle poltrone, su ruote, in caso di non utilizzo  
(per poltrone con piedi da fissare a pavimento in file diritte)  
Accessory system allowing the armchairs to be moved, on castors, when not in use  
(for armchairs with floor fixing feet in straight rows)



Tavoletta di scrittura ribaltabile a scomparsa  
Tip-up foldaway writing tablet



Tavolino di scrittura ribaltabile su base singola mod. T200  
Tip-up writing tablet on single-base mod. T200



Elemento di identificazione fila e numerazione posto  
Row identification and seat numbering element

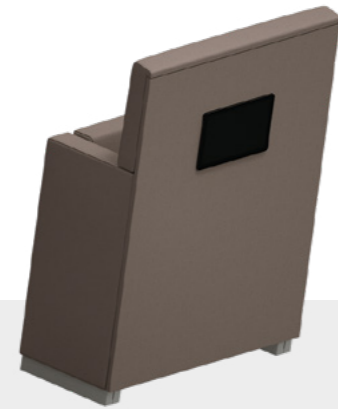

Predisposizione per dispositivi audio-video (su progetto)  
Provision for audio/video devices (on project)



Tavolino retro-schienale ribaltabile con movimento anti-panico  
Backrest tip-up table with anti-panic movement



Retro-schienale in legno verniciato  
Painted wood backrest panel



F50







### Sedile e schienale

Sedile e schienale con struttura interna in multistrato, imbottitura in poliuretano espanso indeformabile a combustione ritardata, rivestimento in tessuto, ecopelle o pelle.

Sedile ribaltabile a gravità, dotato di perni di rotazione in acciaio.

Schienale inclinato e sagomato grazie alla struttura interna curvata che garantisce una maggiore comodità.

L'installazione può avvenire su piano orizzontale, inclinato o su gradoni, in file diritte o in curva (raggio minimo 8 m.), con interasse variabile da 53 a 60 cm.

### Seat and backrest

Seat and backrest with plywood internal structure, fire-retardant, crushproof expanded polyurethane padding, with fabric, eco-leather or leather covering.

Gravity tip-up seat, with steel rotation pins. Inclined and shaped backrest that ensure a better comfort thanks to the curved internal structure.

Installation on horizontal and inclined floor or on steps, in straight or curved rows (minimum radius 8m.) with variable centre-to-centre distance from 53 to 60 cm.



### Comfort

Poltrona per sale conferenze, auditorium e spazi polivalenti, che si qualifica per il comfort, la versatilità e l'ampia disponibilità di accessori con cui è possibile personalizzare ogni intervento su specifiche esigenze di progetto.

### Comfort

Armchair for conference rooms, auditoriums and multi-purpose spaces, characterised by comfort, versatility and a wide range of accessories with which it is possible to personalise every intervention to meet specific project needs.

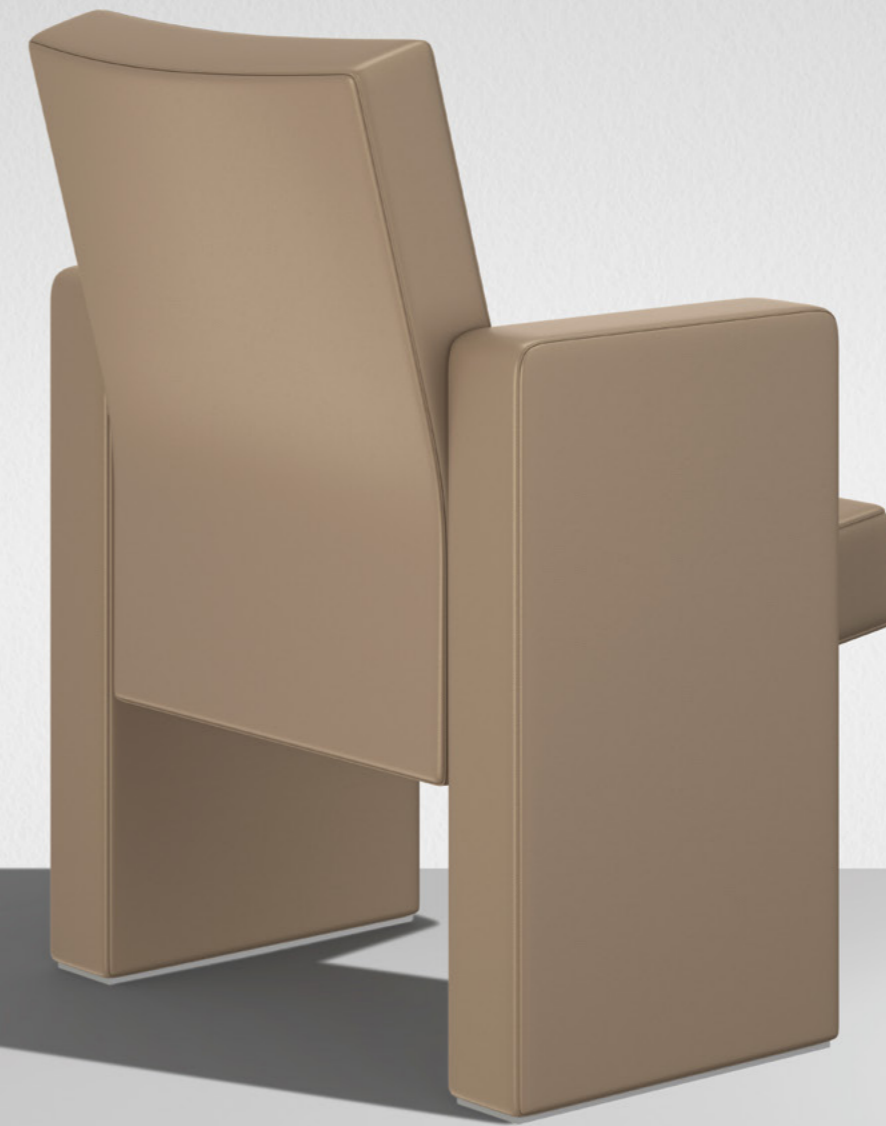



## Fiancate

Realizzate con le stesse caratteristiche di sedile e schienale, le fiancate sono corredate di blocco in alluminio per l'inserimento dei perni di rotazione e di sostegno del sedile.

Le fiancate destre possono essere dotate di tavoletta di scrittura ribaltabile con movimento anti-panico a scomparsa. Piedi di ancoraggio a pavimento in profilato d'acciaio verniciato.



## Sides

Realised with the same features of seat and backrest, sides are equipped with an aluminium block for the insertion of rotation and seat support pins. Right sides are available with tip-up writing tablet with foldaway anti-panic movement. Floor fixing feet in painted steel profile.



Wanda Metropolitano Stadium, Press Room  
Madrid, Spain





New FANUC Italia Headquarters  
Lainate (MI), Italy





Finiture - Finishes



## Dimensioni - Dimensions

F50

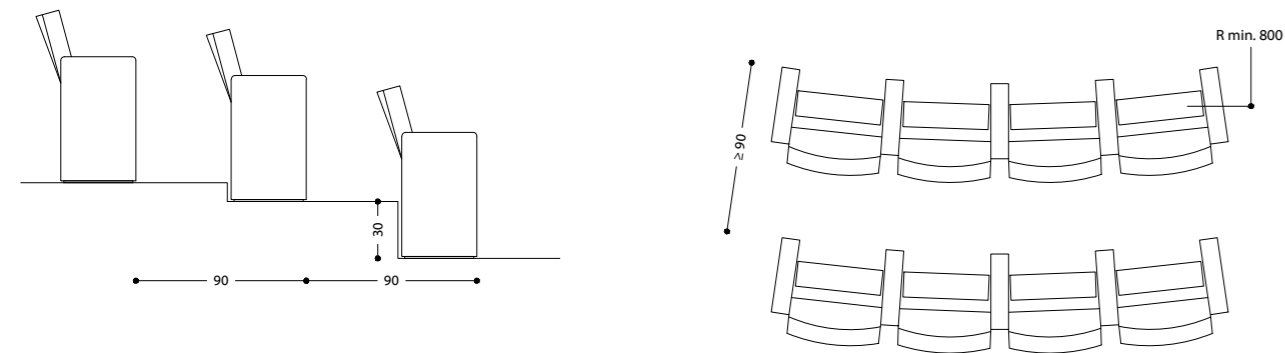
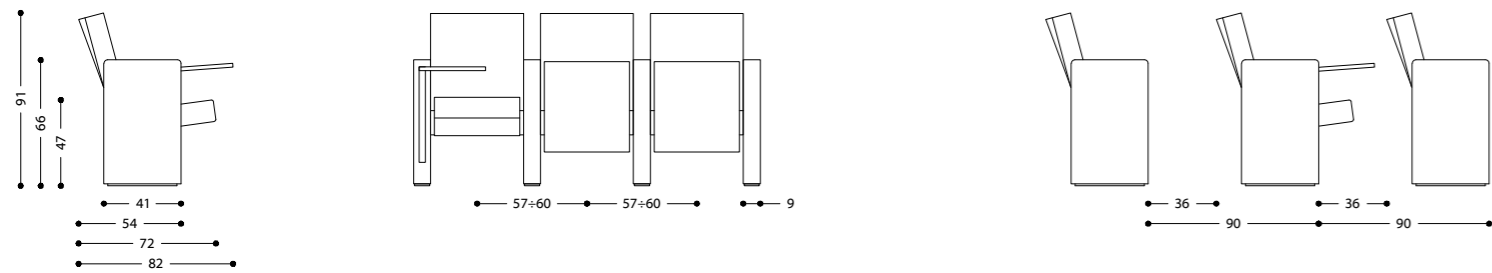
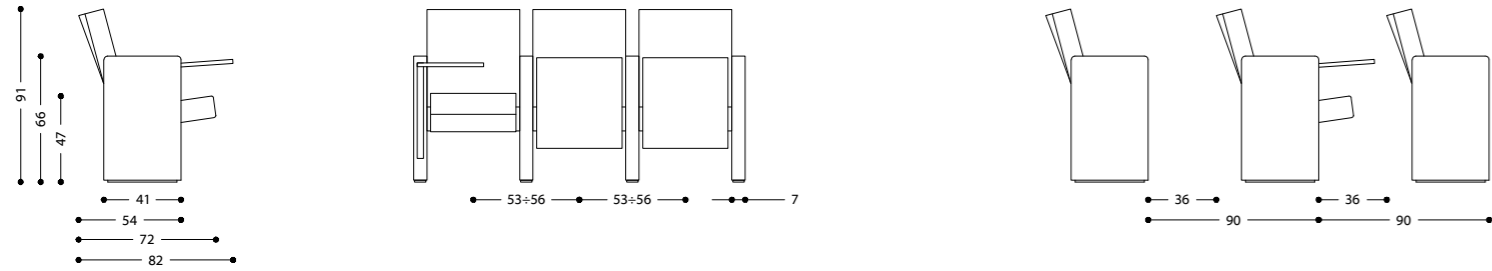

80

## Accessori - Accessories



Elemento di identificazione fila e numerazione posto  
Row identification element and seat numbering element



Predisposizione per l'elettrificazione (presa elettrica su richiesta)  
Provision for electric power supply (socket on demand)



Tavoletta di scrittura ribaltabile a scomparsa  
Tip-up foldaway writing tablet



Sistema che permette l'amovibilità delle poltrone, su ruote, in caso di non utilizzo  
(per poltrone con piedi da fissare a pavimento in file diritte)  
Accessory system allowing the armchairs to be moved, on castors, when not in use  
(for armchairs with floor fixing feet, in straight rows)



Carter retro-schienale basso in legno verniciato  
Painted wood low backrest panel



Tavolino di scrittura ribaltabile su base singola mod. T200  
Tip-up writing table on single base mod. T200

81



# C100

Baldanzi & Novelli







### Fiancate

Fiancata a terra disponibile con profondità standard di (34 cm) o maggiorata (44 cm). Pannelli laterali in due altezze con rivestimento in tessuto, in pelle o in essenze naturali e con telaio strutturale in acciaio a vista.

Nella versione su barra le fiancate intermedie sono tamponate con pannelli laterali che si appoggiano sulla trave, mentre quelle iniziali possono anche arrivare fino a terra.

L'installazione può avvenire su piano orizzontale, inclinato o su gradoni, in file diritte o in curva.

### Poggia-braccio

Poggia-braccio riportato in massello di legno verniciato, coordinato alle fiancate, oppure interamente imbottito e rivestito in tessuto o pelle.

### Sides

Floor-level side available in standard depth (34 cm) or increased depth (44 cm). Two-height side panels with fabric, leather or natural wood covering and visible structural steel frame.

In the beam-mounted version the intermediate sides are filled using side panels that rest on the beam, whereas the starting sides can reach the ground.

Installation on horizontal and sloped flooring or on steps, in straight or curved rows.

### Armrest

Added painted solid wood armrest, coordinate with the sides, or fully padded and covered with fabric or leather.





### Sedile e schienale

Sedile con dispositivo a gravità che ne consente il ribaltamento con movimento auto-frenante. Schienale, alto o basso, posizionabile con due diverse angolazioni per favorire sempre una perfetta visuale, sia in platea che in galleria.

### Personalizzazione

Poltrona qualificata da una serie di accessori funzionali, che consentono di personalizzare ogni intervento con soluzioni specifiche. Caratterizzata da un design nitido e lineare, esprime forti requisiti ergonomici di comfort.

### Seat and backrest

A gravity device allows the seat to tip up with a cushioned movement. High or low backrest available with inclination at two different angles to enable a perfect view at all times, both in stalls and in gallery.

### Customisation

Armchair qualified by a series of functional accessories that enable each installation to be customised with specific features. Characterised by a straightforward design, this armchair provides high levels of ergonomic comfort and safety.







## Tipologie

Prodotta sia con fiancata a terra che su barra, la poltrona si adatta a qualsiasi progetto (è disponibile anche un sistema accessorio per l'amovibilità delle poltrone). La versione su barra è disponibile anche con piedi antiribaltamento senza fissaggio a pavimento. La fiancata può essere completamente imbottita o in legno verniciato.

## Versions

Produced both with floor level side and on beam, the armchair is suitable for any project (an accessory system to move the armchairs is also available). The beam mounted version is also available with anti-tilt feet that do not require floor fixing. The side can be fully padded or in painted wood.









Finiture - Finishes



## Dimensioni - Dimensions

C100 schienale basso - C100 with low backrest

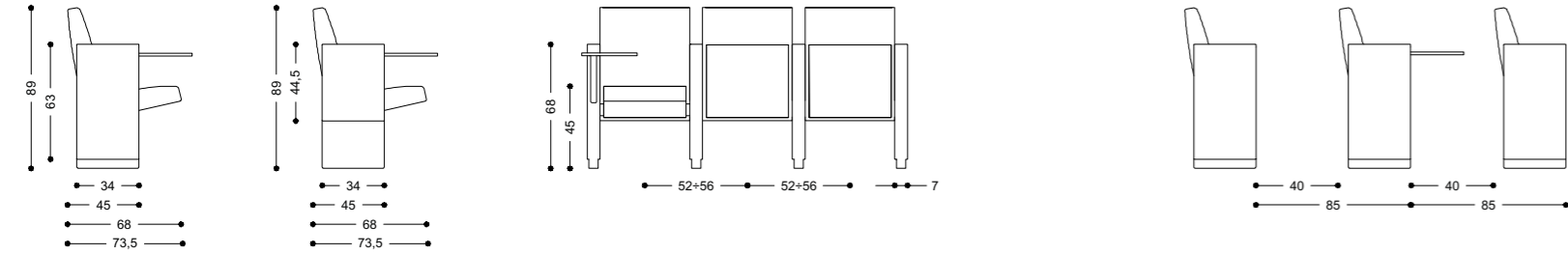

C100 schienale basso - C100 with low backrest

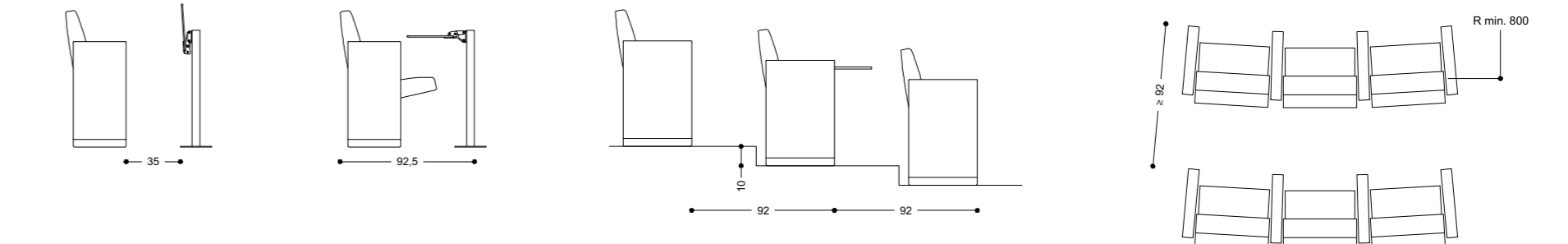
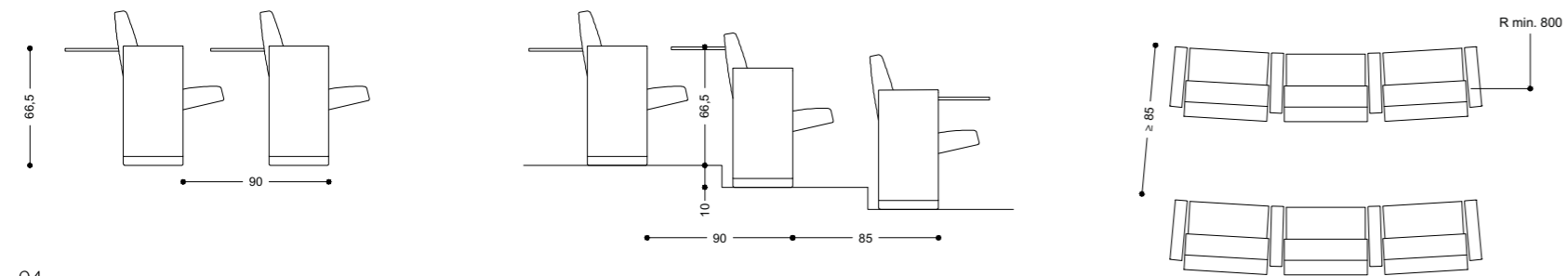
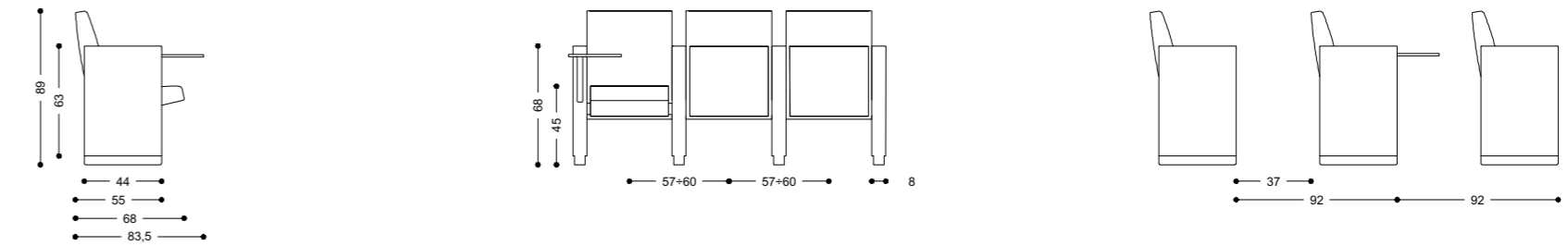
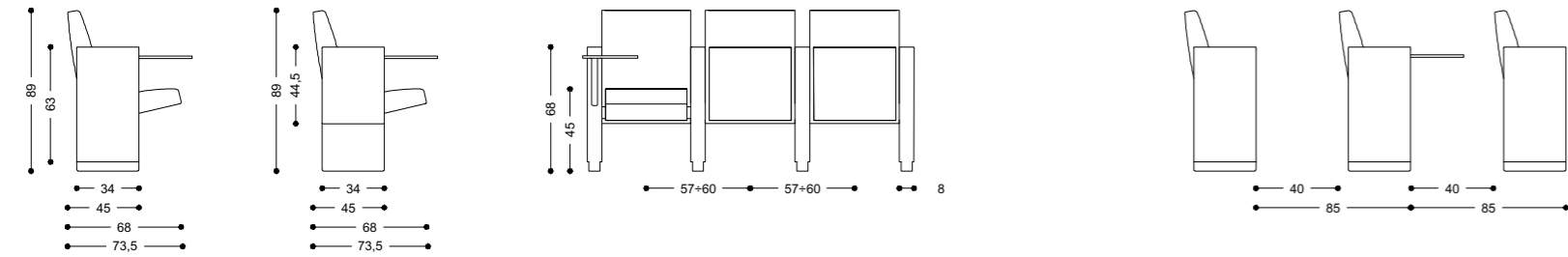
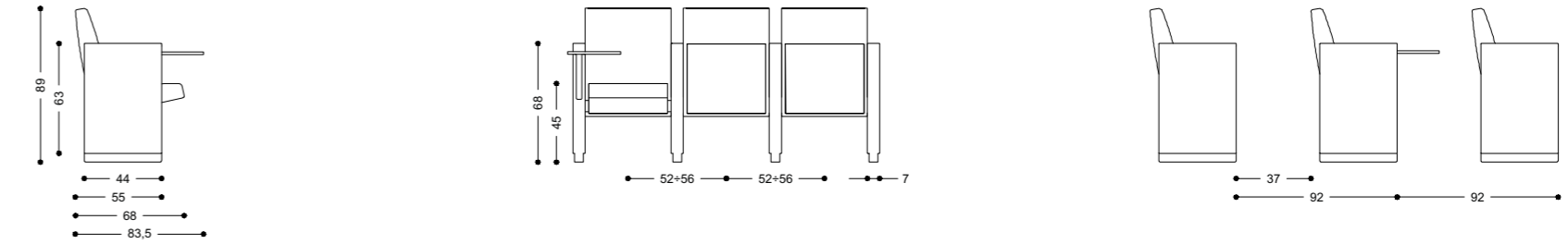



# Dimensioni - Dimensions

C100 schienale alto - C100 with high backrest

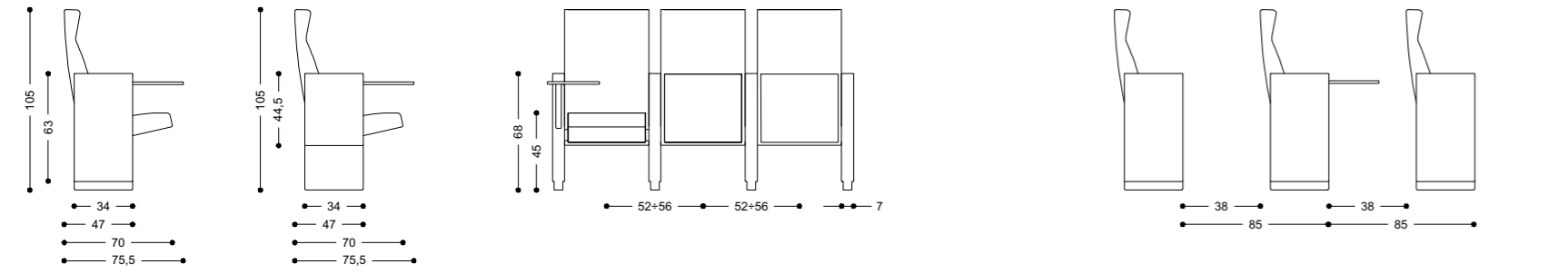

C100 schienale alto - C100 with high backrest

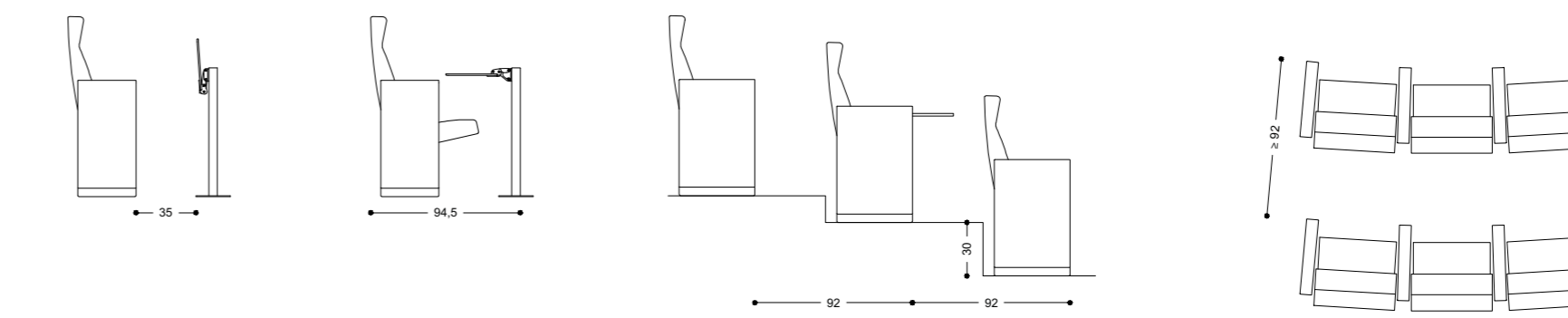
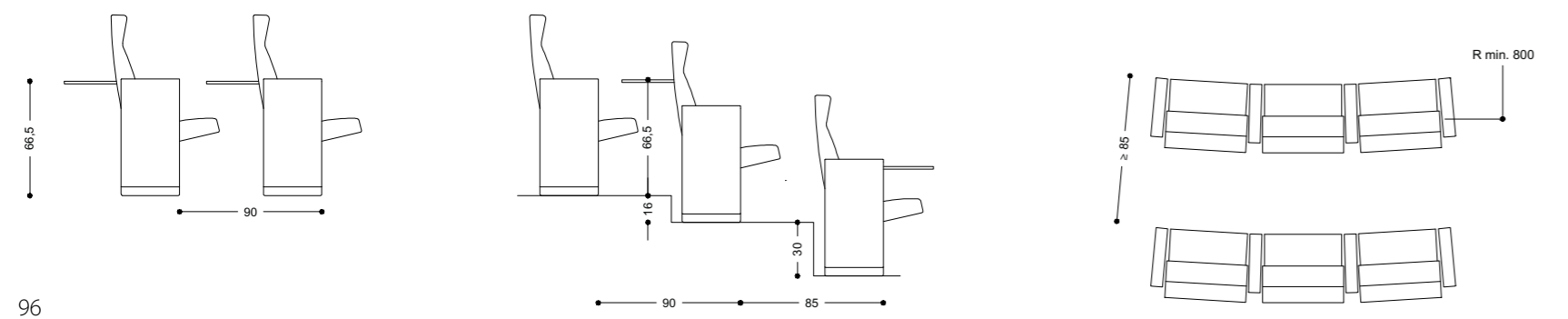
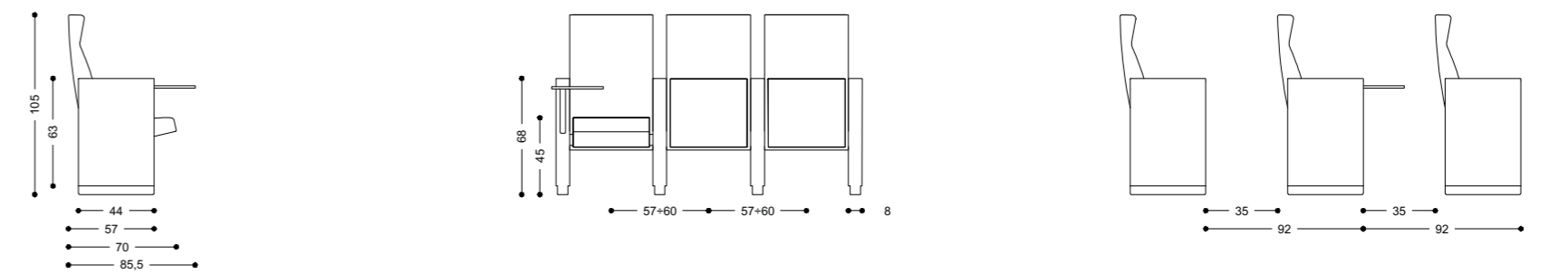
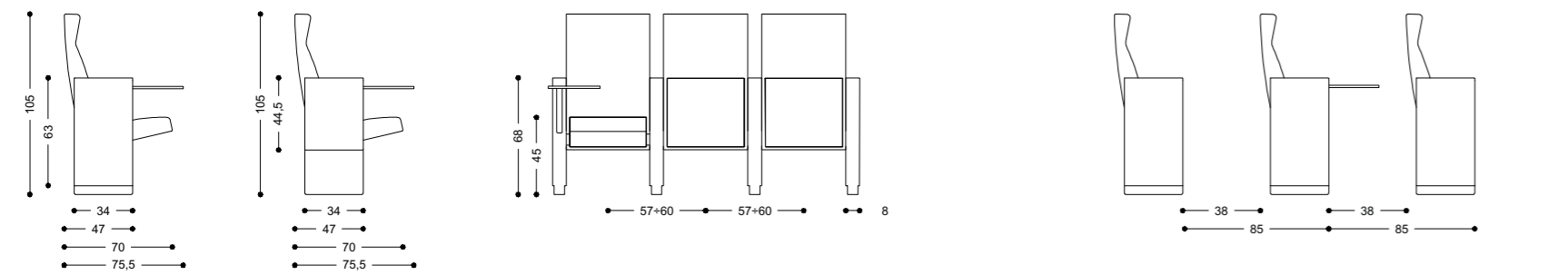
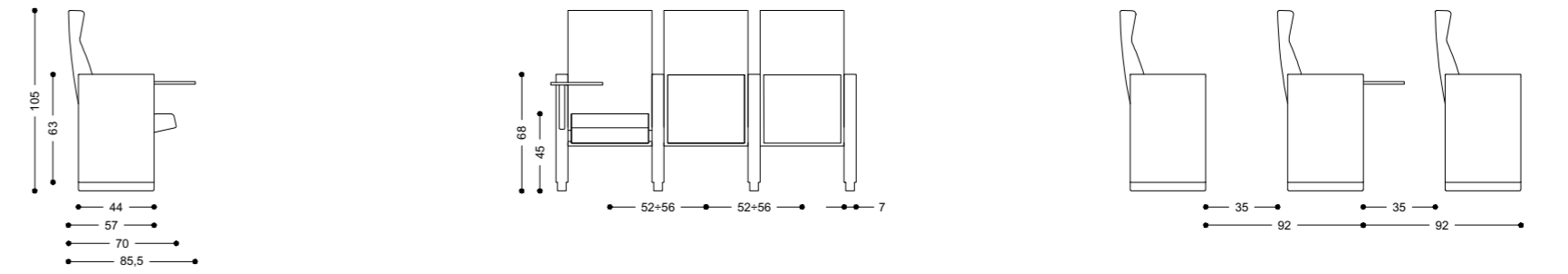



## Dimensioni - Dimensions

C100 su barra schienale basso - C100 on beam with low backrest

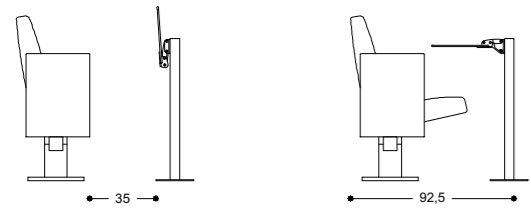
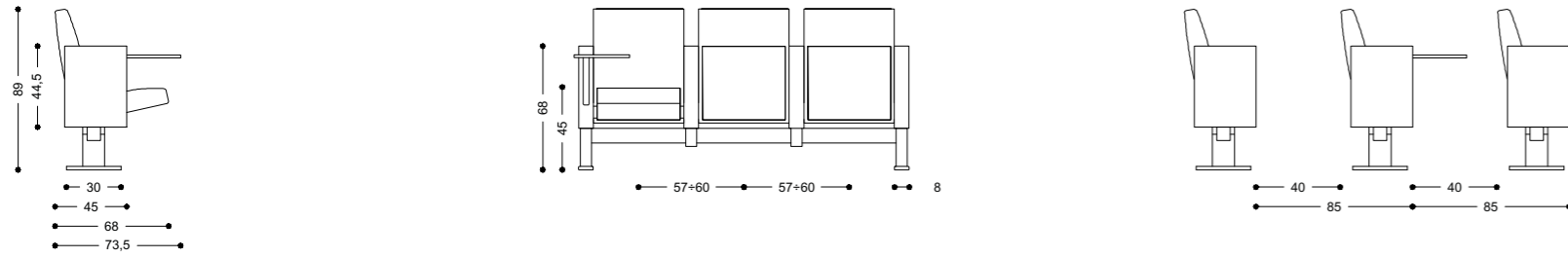
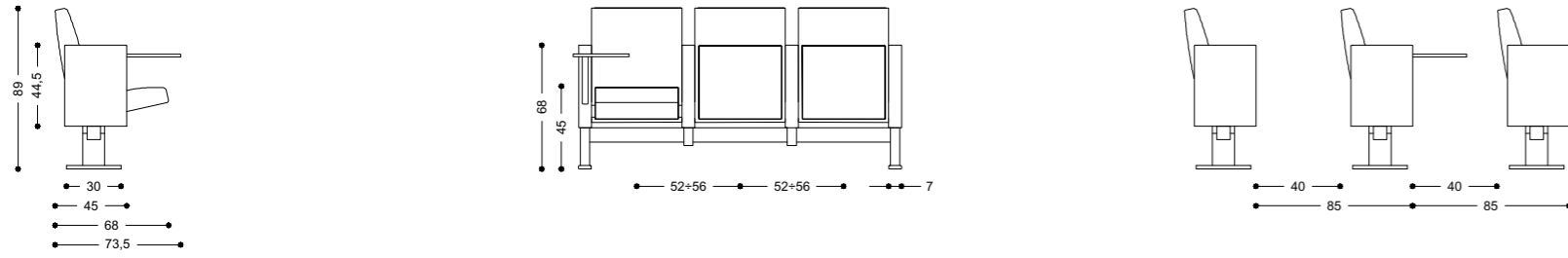

C100 su barra schienale basso - C100 on beam with low backrest

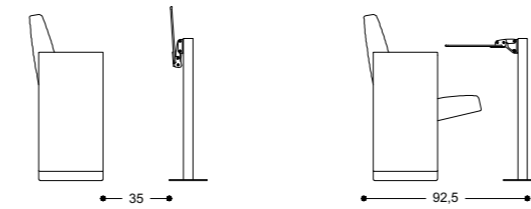
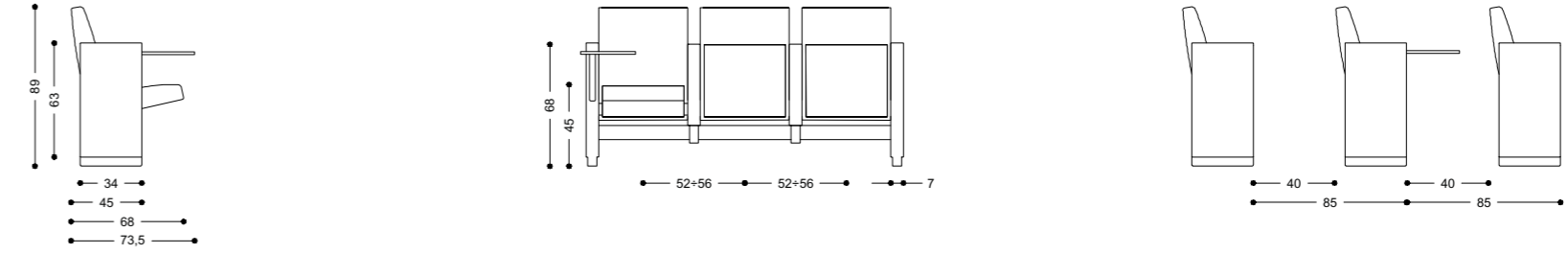



## Dimensioni - Dimensions

C100 su barra schienale alto - C100 on beam with high backrest

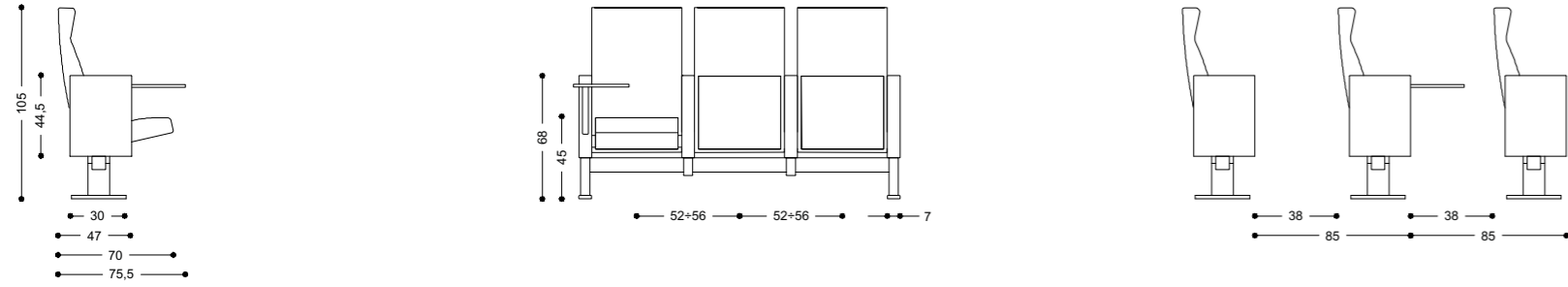

C100 su barra schienale alto - C100 on beam with high backrest

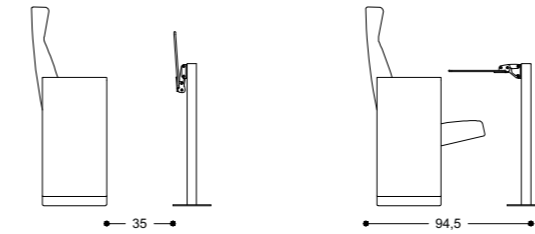
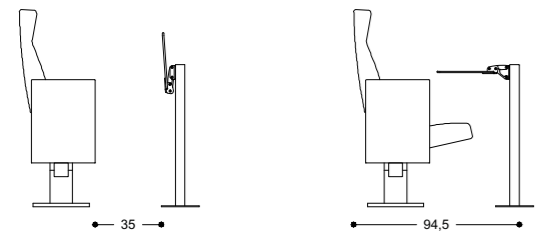
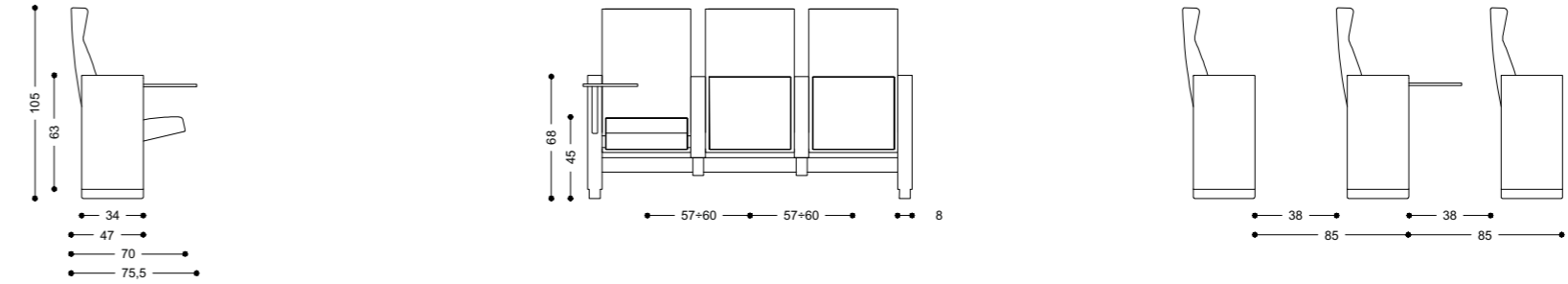
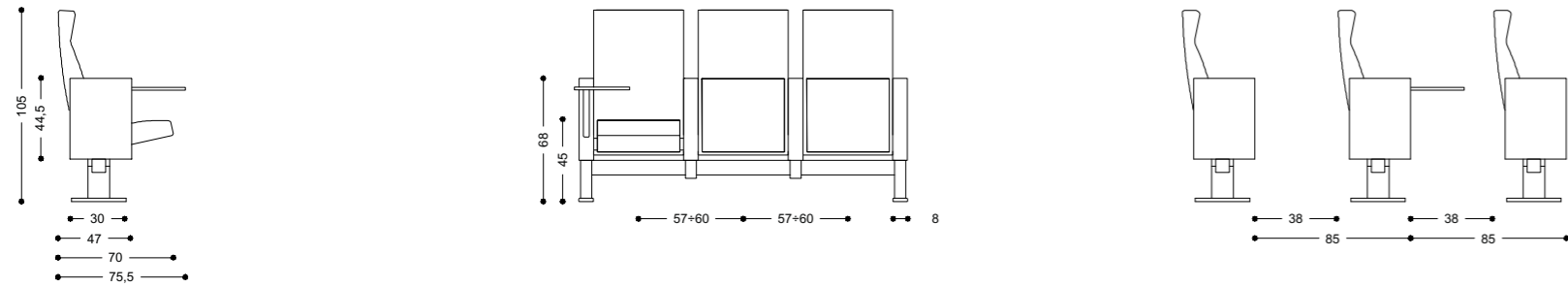
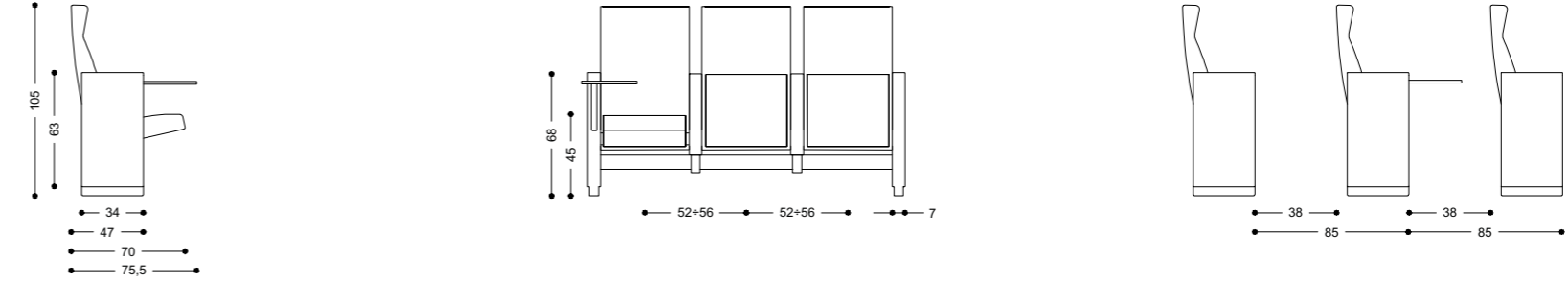



Accessori - Accessories



Elemento di identificazione fila e numerazione posto  
Row identification and seat numbering element



Predisposizione per l'elettrificazione (presa elettrica su richiesta)  
Provision for electric power supply (socket on demand)



Pannello sotto-sedile in legno verniciato  
Painted wood under seat panel



Tavoletta di scrittura ribaltabile a scomparsa  
Tip-up foldaway writing tablet



Piede anti-ribaltamento per versione su barra  
Anti-tilt foot with registers for version on beam



Sistema che permette l'amovibilità delle poltrone, su ruote, in caso di non utilizzo  
(per poltrone con piedi da fissare a pavimento in file diritte)  
Accessory system allowing the armchairs to be moved, on castors, when not in use (for armchairs with floor fixing feet, in straight rows)



Retro-schienale alto in legno verniciato  
Painted wood high backrest panel



Carter retro-schienale basso in legno verniciato  
Painted wood low backrest panel



Tavolino retro-schienale ribaltabile con movimento anti-panico  
Tip-up backrest table with anti-panic movement



Tavolino di scrittura ribaltabile su base singola mod. T200  
Tip-up writing tablet on single-base mod. T200



# Mura

Gino Gamberini

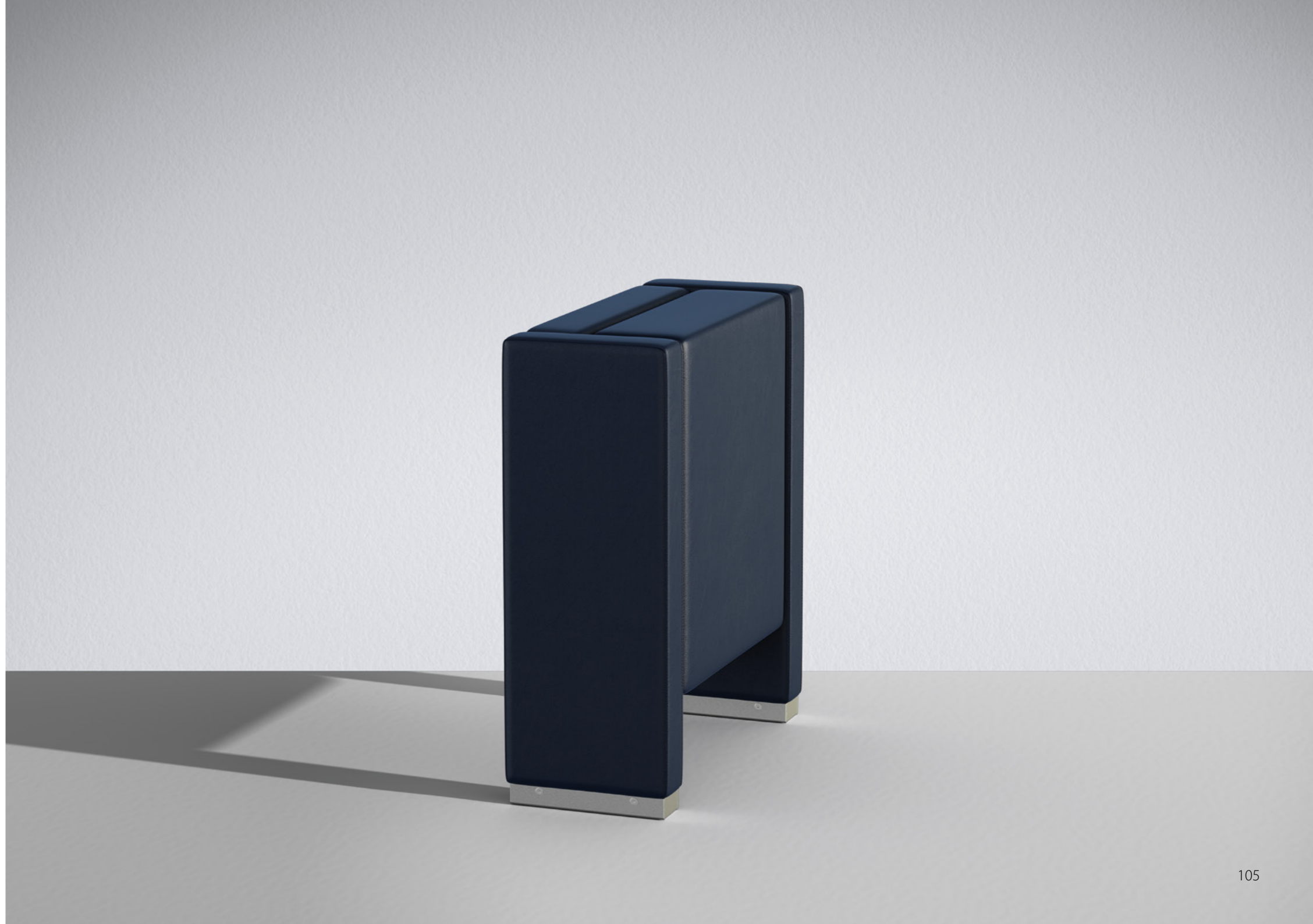



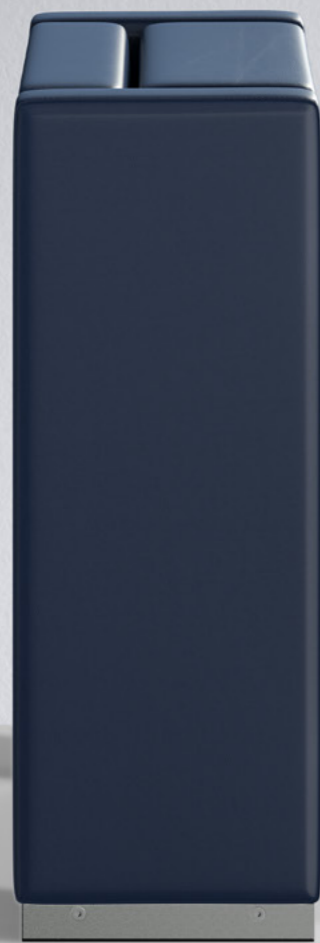

### Forma e funzione

Poltrona compatta ed elegante, progettata per auditorium e sale conferenze. Coniuga aspetti funzionali e ricerca formale, dimensioni ridotte e comfort elevato.



### Form and function

Compact and elegant armchair, designed for auditoriums and conference halls. It combines functional aspects and formal research, reduced size and high comfort.





### Compasso d'Oro

Mura, nella sua prima versione, ha vinto il prestigioso premio Compasso d'Oro ADI "per qualità formale e funzionale nella completezza dell'immagine".

### Tecnologia invisibile

Sedile e schienale con struttura in multistrato. Imbottiture in poliuretano espanso indeformabile. Fiancata con struttura interna portante in multistrato. Piede di ancoraggio a pavimento in profilato di acciaio verniciato. L'installazione può avvenire su piano orizzontale, inclinato o su gradoni, in file diritte.

### Compasso d'Oro

The first version of Mura won the prestigious Compasso d'Oro ADI Award "for its formal and functional quality in the image perfection".

### Invisible technology

Seat and backrest with plywood internal structure. Non-deformable polyurethane foam padding. Side with plywood bearing internal structure. Floor anchor foot in painted steel profile. Installation on horizontal and sloped flooring or on steps, in straight rows.

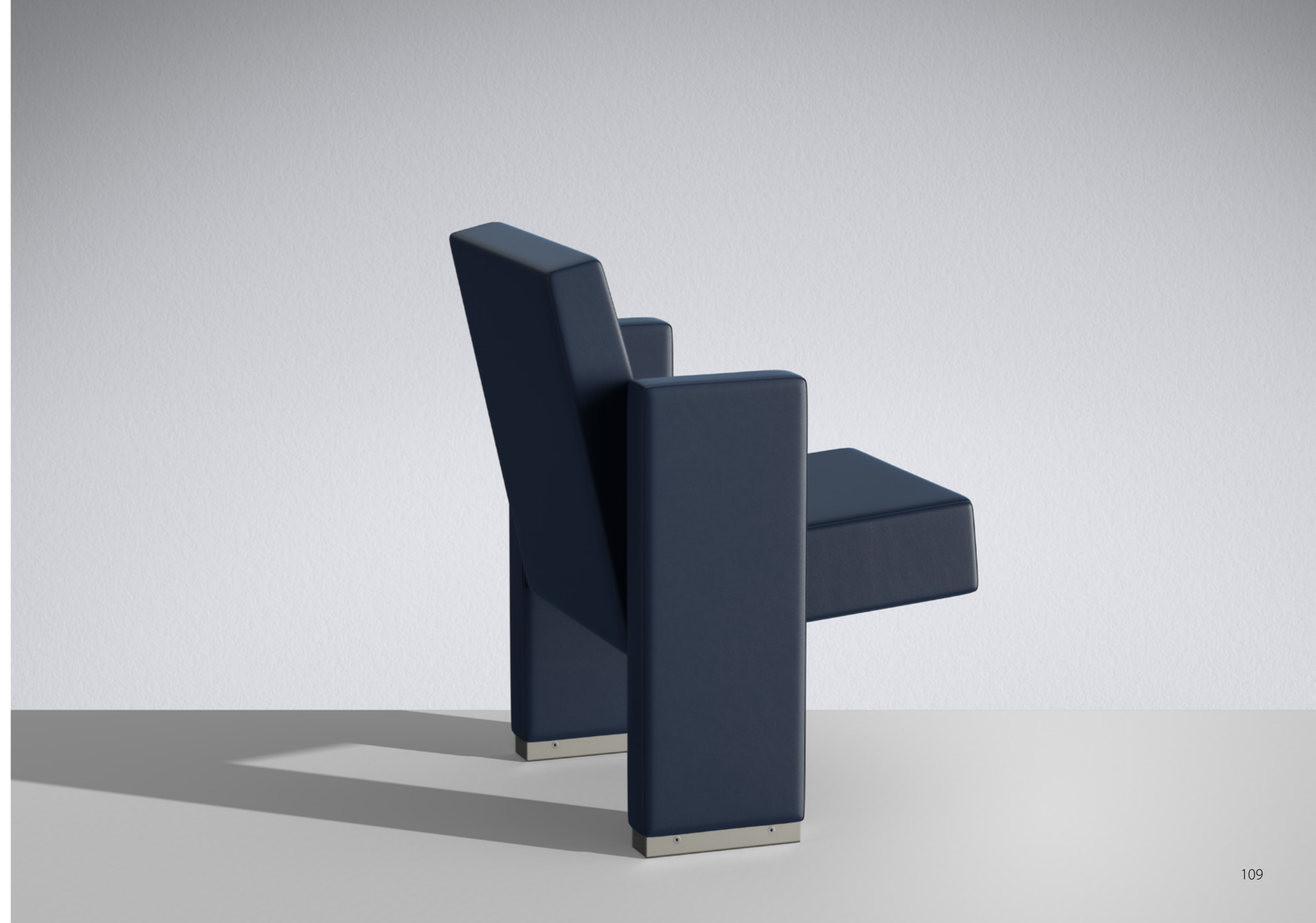



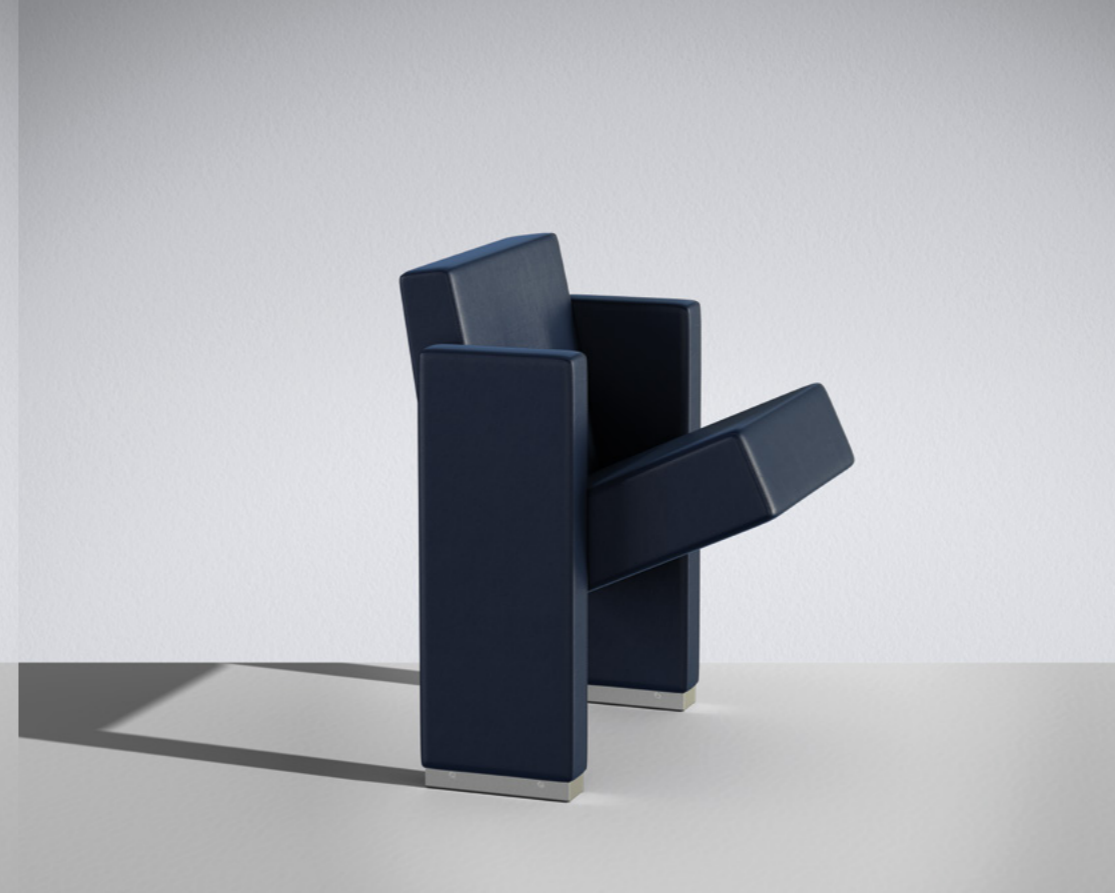
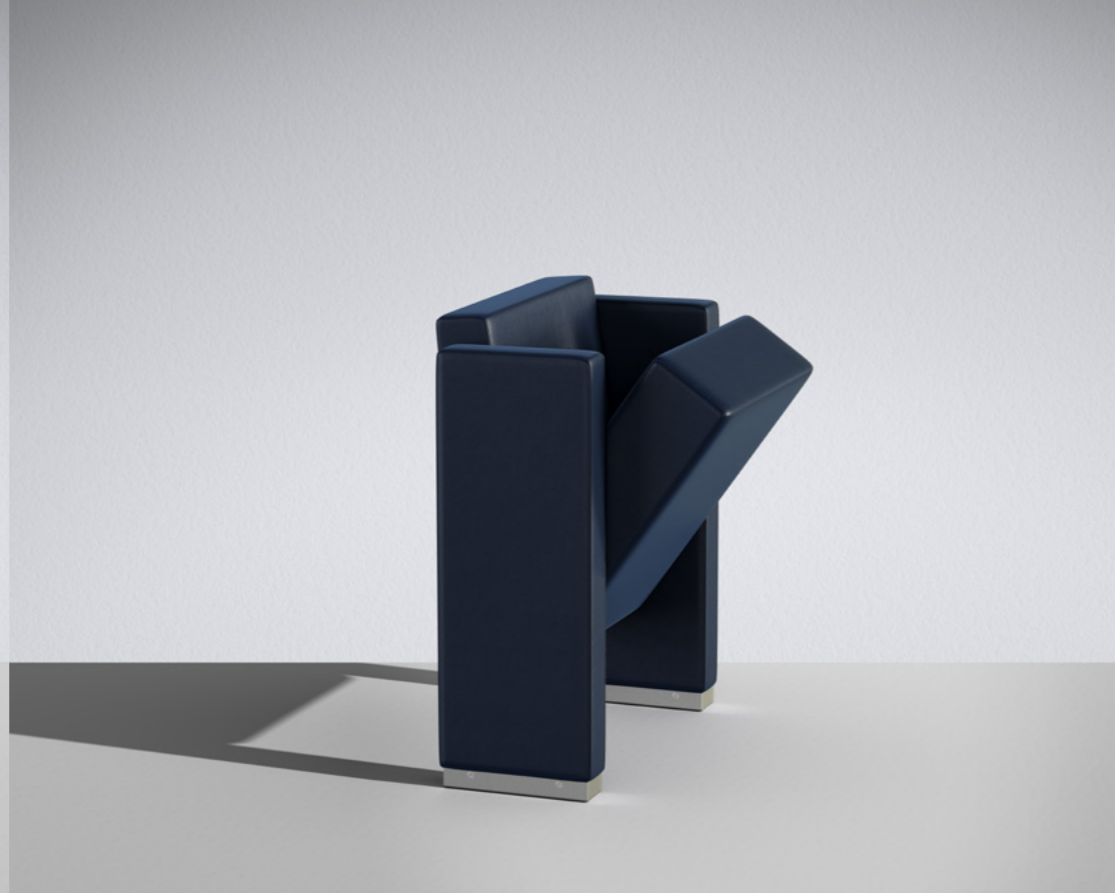
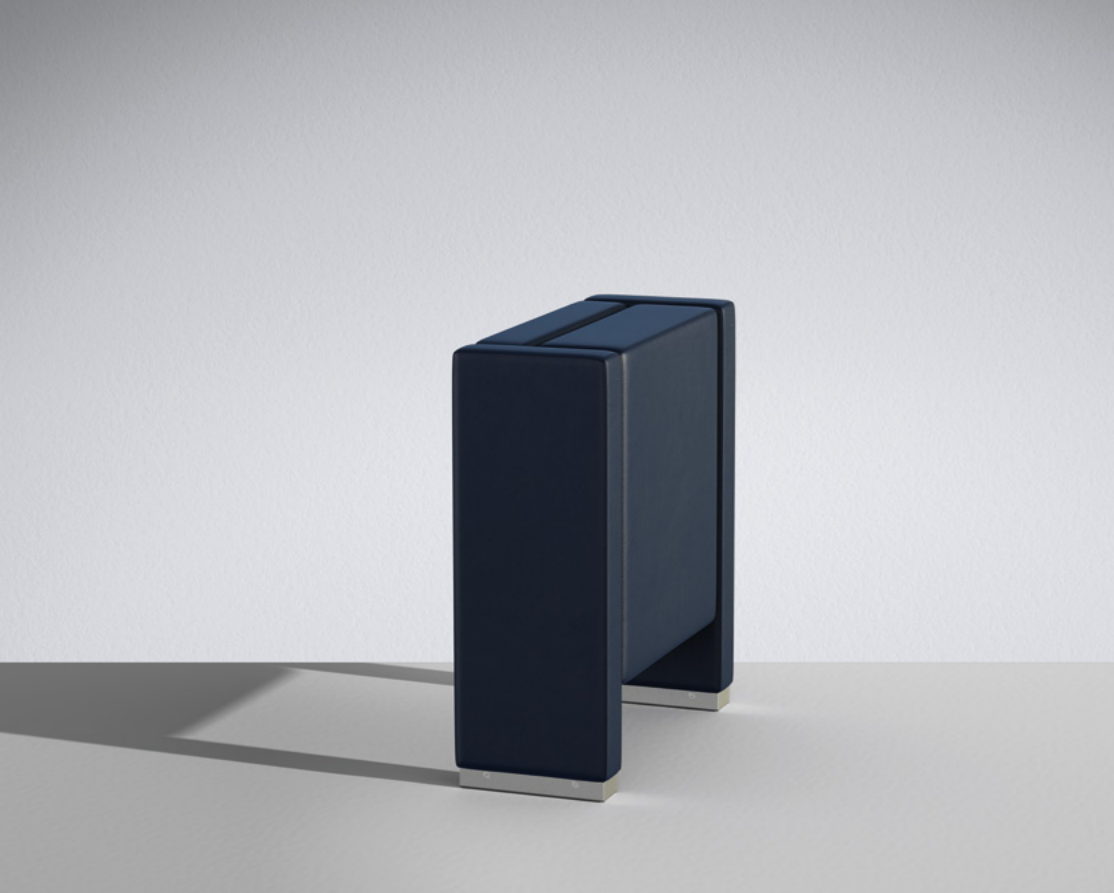

### Meccanismi innovativi

Dispositivo a gravità che, liberando il sedile, ne consente il ribaltamento con movimento ammortizzato. In sincrono, lo schienale si abbassa e verticalizza riducendo le dimensioni di ingombro.

### Innovative mechanisms

Gravity system which releases and tips up the seat with a cushioned movement. The backrest lowers and at the same time moves into a vertical position, reducing overall dimensions.



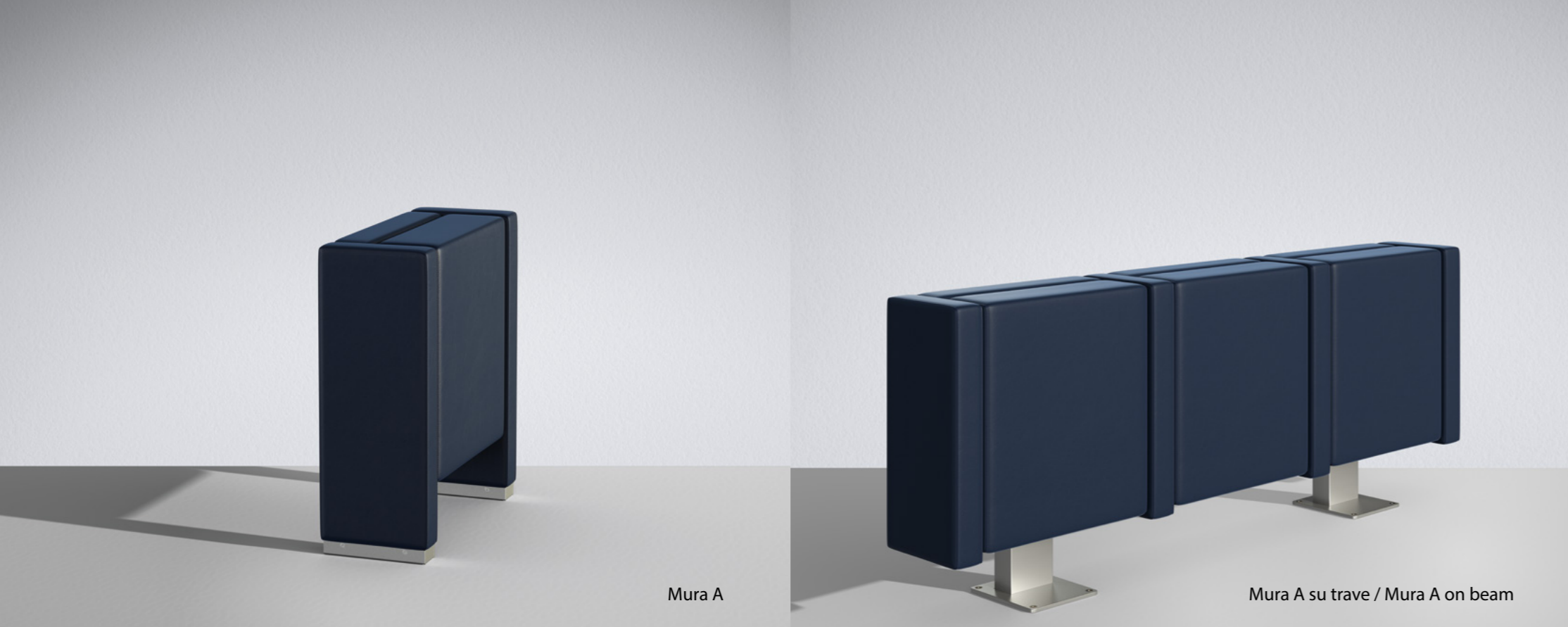

Mura A

Mura A su trave / Mura A on beam

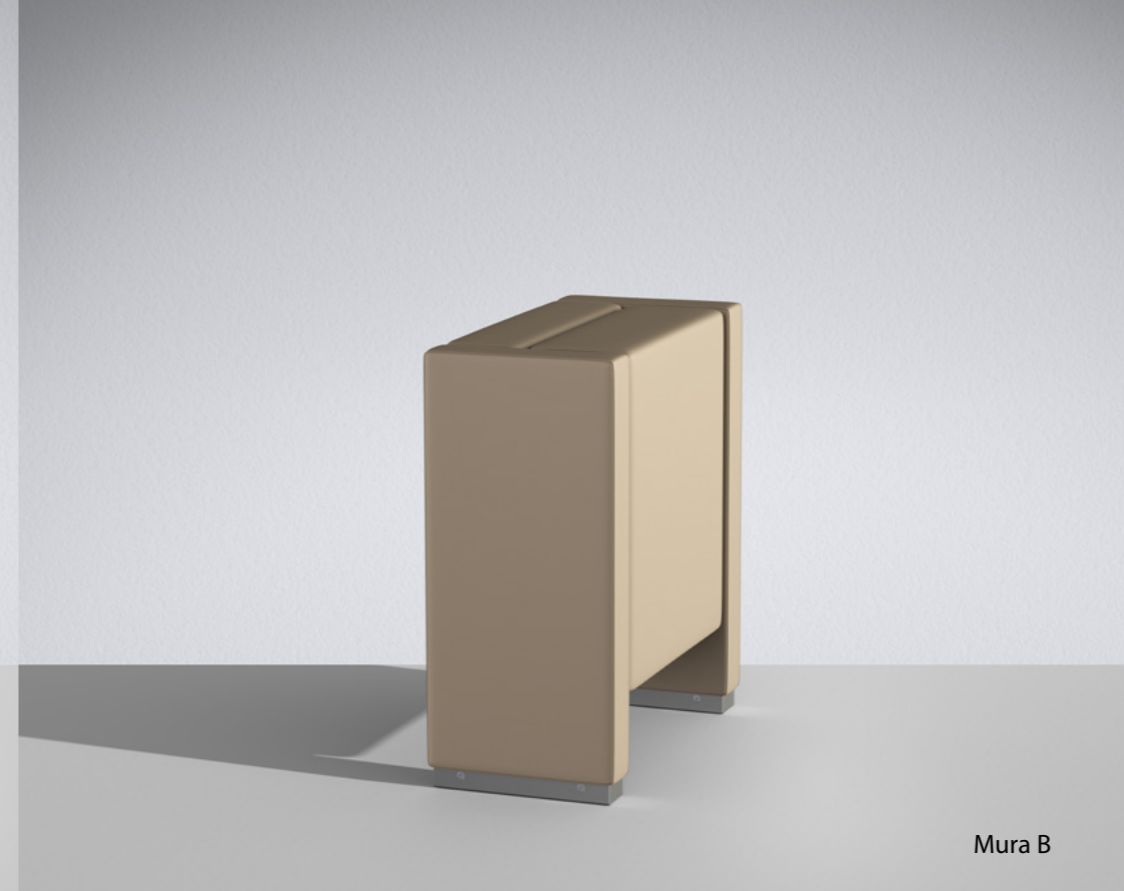

Mura B

Mura B su trave / Mura B on beam

## Tipologie

Versione standard con schienale e sedile chiuso allineati alle fiancate. Variante VIP con schienale più alto. Fiancata prodotta con due profondità, 24 e 30 cm. Base di appoggio a pavimento singola o su barra.

## Versions

Standard version with backrest and closed seat aligned with sides. VIP version with higher backrest. Side produced in two depths, 24 and 30 cm. Single or beam-mounted floor support.



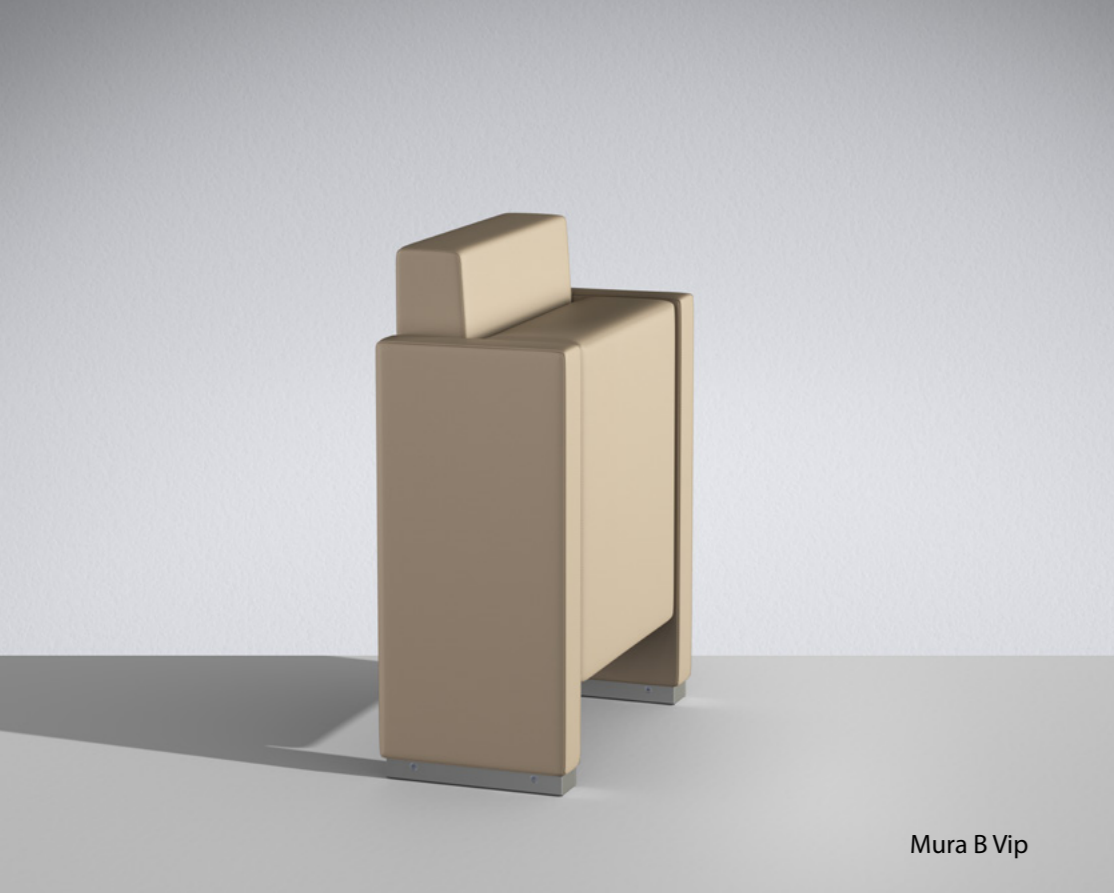

Mura B Vip

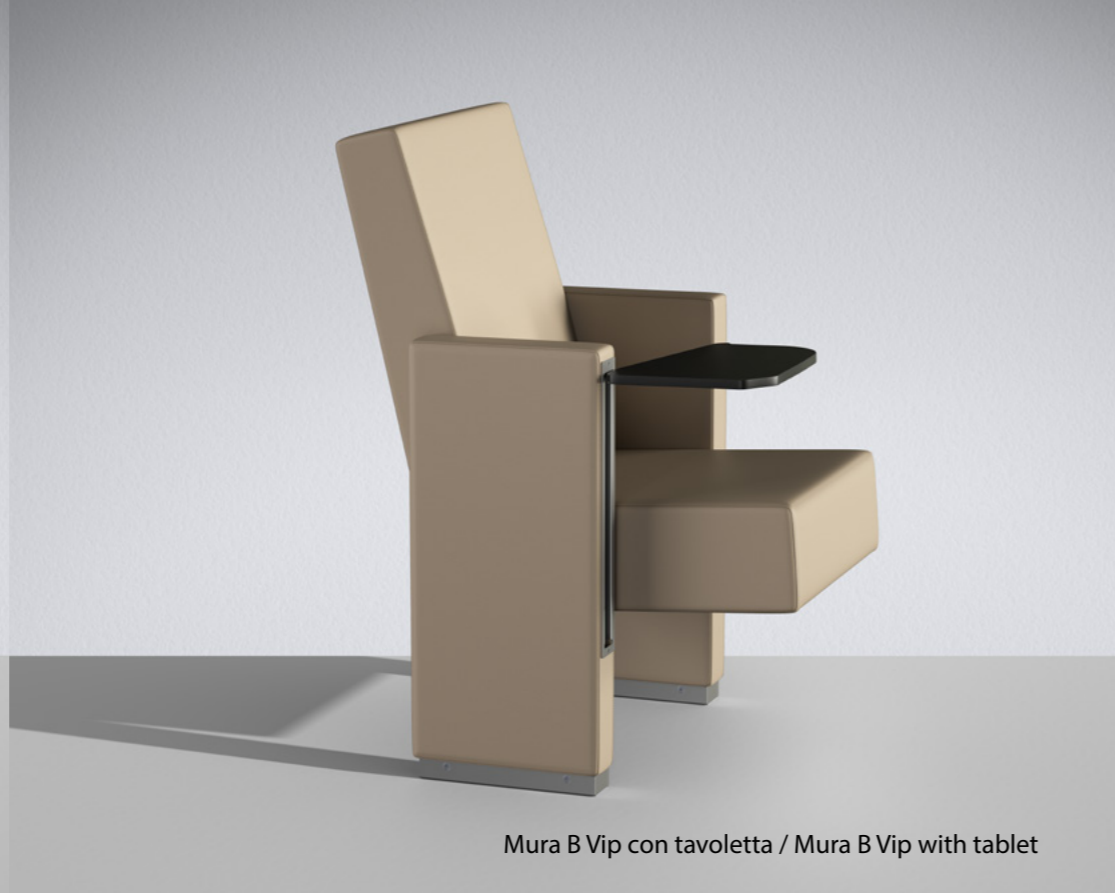

Mura B Vip con tavoletta / Mura B Vip with tablet





Mura "A"

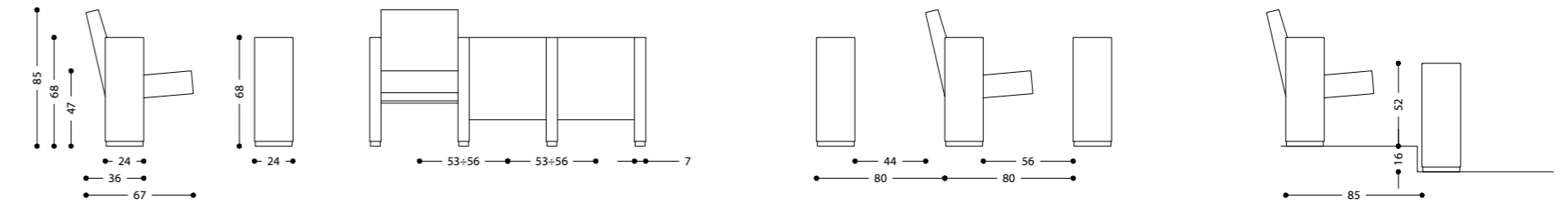

Mura "A" su barra con piede centrale - Mura "A" on beam with central base

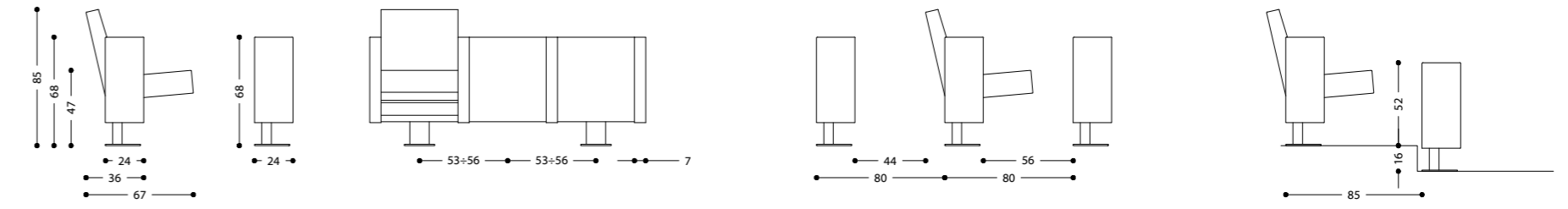



## Dimensioni - Dimensions

Mura "A" Vip

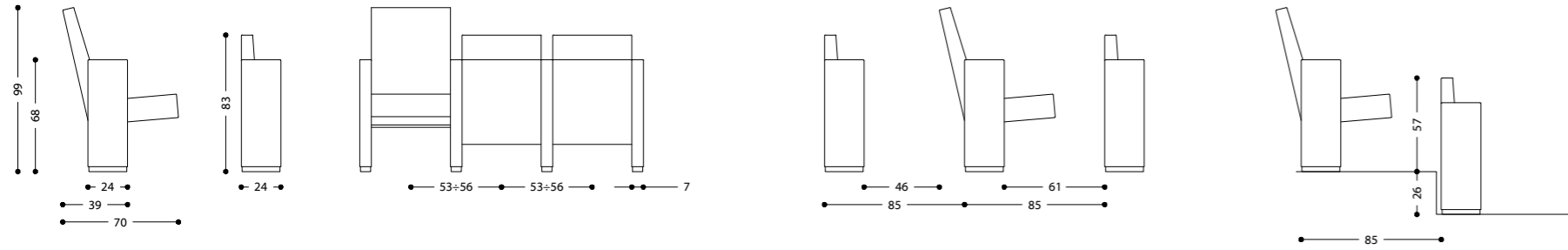

Mura "B"

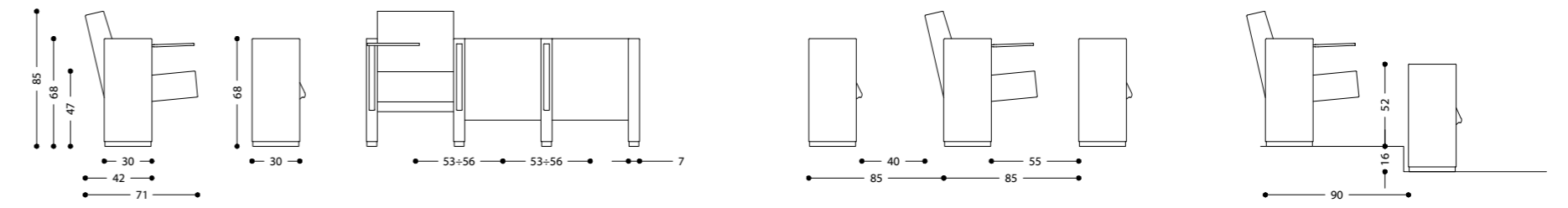

Mura "A" Vip su barra con piede centrale - Mura "A" Vip on beam with central base

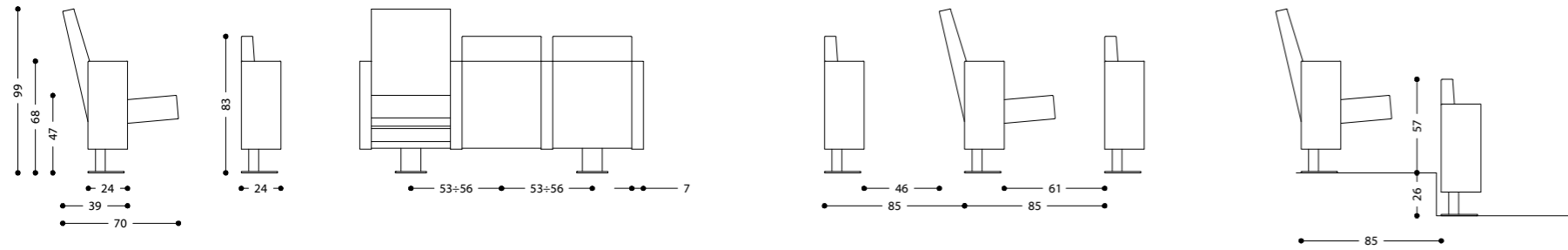

Mura "B" su barra con piede centrale - Mura "B" on beam with central base

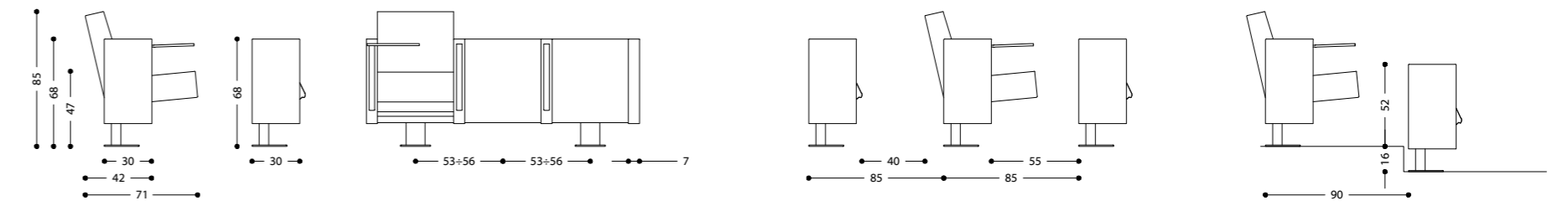



## Dimensioni - Dimensions

### Mura "B" Vip

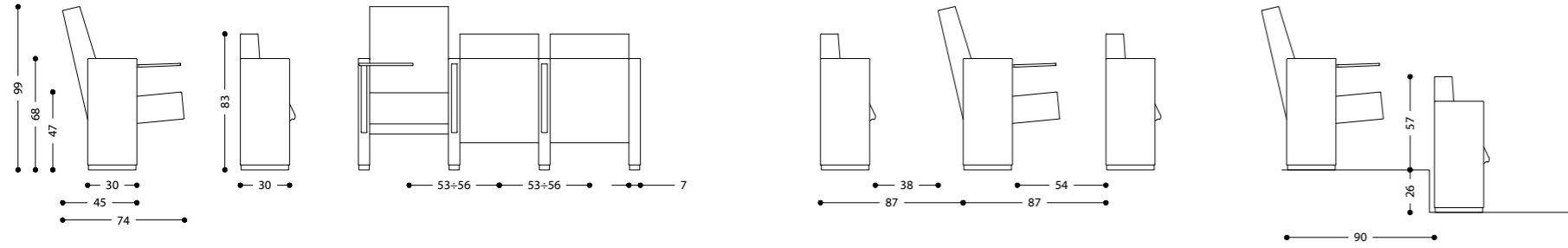

### Mura "B" Vip su barra con piede centrale - Mura "B" Vip on beam with central base

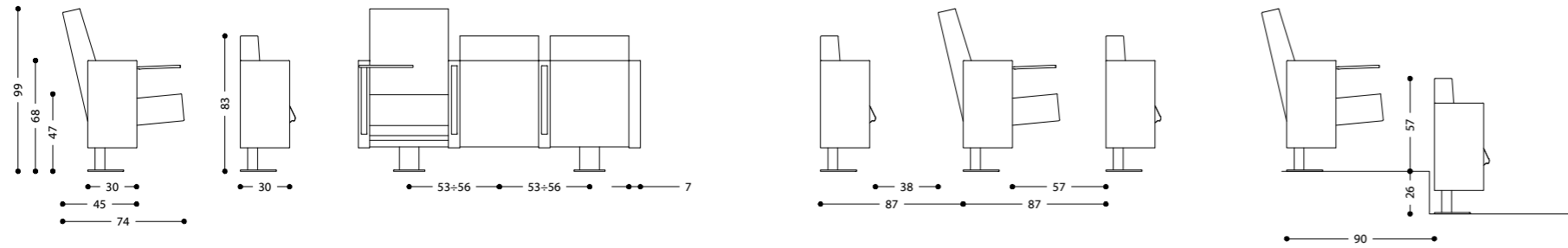

## Accessori - Accessories

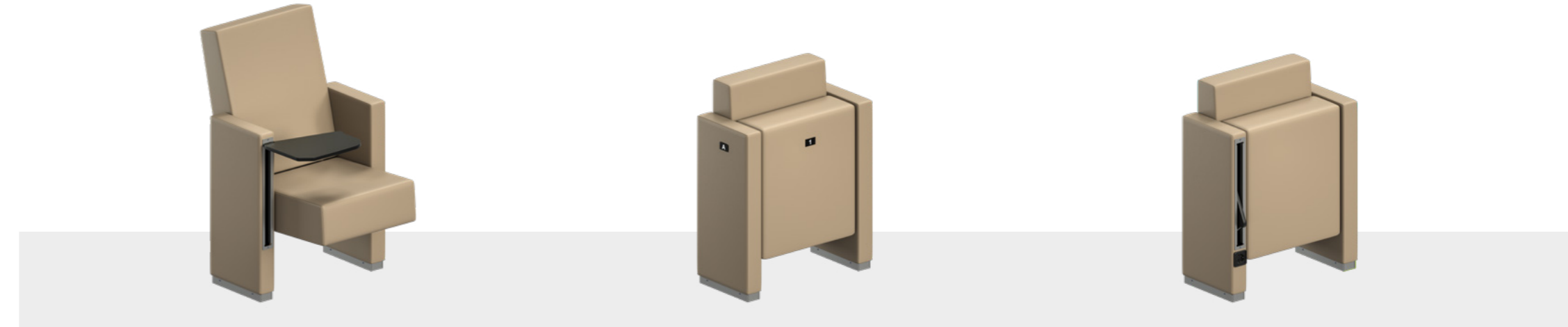

Tavoletta di scrittura ribaltabile a scomparsa (nella fiancata da cm 30)  
Writing tablet, folding away (into the 30 cm side)

Elemento di identificazione fila e numerazione posto  
Row identification and seat numbering element

Predisposizione per l'elettrificazione (presa elettrica su richiesta)  
Provision for electric power supply (socket on demand)



Sistema che permette l'amovibilità delle poltrone, su ruote, in caso di non utilizzo (per poltrone con piedi da fissare a pavimento in file diritte)  
Accessory system allowing the armchairs to be moved, on castors, when not in use (for armchairs with floor fixing feet in straight rows)



# Tulip

Bartoli Design







### **Innovativo sistema di apertura**

Abbassando il sedile anche i braccioli vengono trascinati nella stessa posizione, grazie all'innovativo sistema di apertura sincronizzata. Il ritorno ammortizzato del sedile chiude automaticamente anche i braccioli condivisi con altre postazioni solo se questi non sono in uso.

### **Comfort e design**

Poltrona progettata per soddisfare elevate prestazioni funzionali e di comfort; qualificata a livello di design da un profilo compatto e arrotondato che ne favorisce l'inserimento in ambiti architettonici diversificati.

### **Innovative opening system**

When the seat is lowered, the arms are also brought down into the same position, thanks to the synchronised innovative opening system. Cushioned return of the seat also closes the arms shared with other positions automatically, but only when they are not in use.

### **Comfort and design**

Designed to satisfy demanding functional and comfort requirements, this armchair is formally qualified by a compact, rounded contour which facilitates its inclusion in different architectural settings.



### Struttura e materiali

Sedile, schienale e braccioli con struttura interna in tubolare di acciaio, imbottitura di poliuretano espanso schiumato a freddo, indeformabile, a combustione ritardata e rivestimento in pelle o tessuto. Barra portante in tubo di acciaio verniciato, base in tubolare metallico, rivestita da carter in ABS in colore coordinato alla barra.

### Structure and materials

Seat, backrest and arms with tubular steel internal structure padding in flame-retardant, cold-moulded, non-deformable polyurethane foam, with leather or fabric covering. Support beam in painted tubular steel, support base in tubular metal, covered with an ABS guard, colour-coordinated with the beam.



### Tipologie

Versione singola con doppio bracciolo e su barra a formare file diritte con basi portanti fissate a pavimento mediante piede di ancoraggio nascosto da carter in ABS verniciato.

L'installazione può avvenire su piano orizzontale, inclinato o su gradoni, in file diritte.

### Versions

Beam-mounted single version with double arm, arranged in straight rows with floor fixed, load-bearing bases by means of anchor foot covered by a painted ABS collar.

Installation on horizontal and inclined flooring or on steps, in straight rows.





Multimedia Center "La Passerelle"  
Vitrolles, France



Italian Football Federation, Umbria  
Perugia, Italy





West Plaza  
Paris, France

Finiture - Finishes



## Dimensioni - Dimensions

Tulip su base singola - Tulip on single base

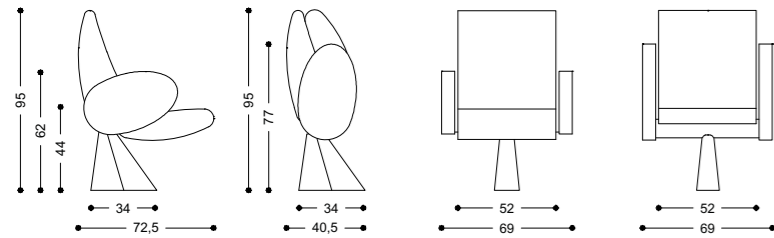
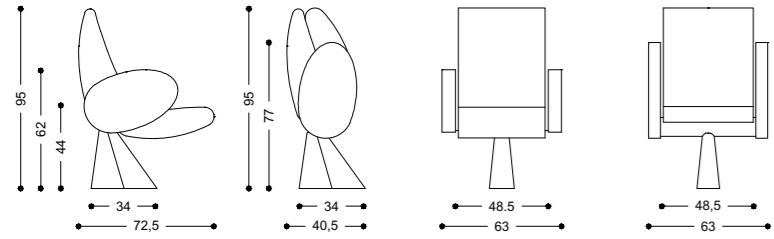

Tulip su barra - Tulip on beam

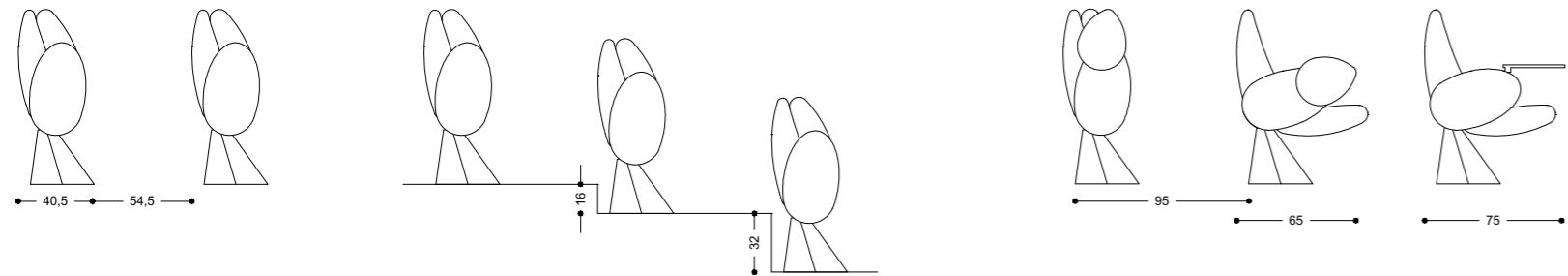
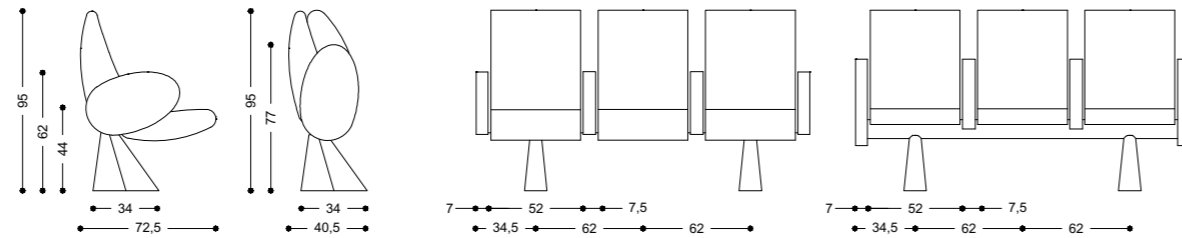
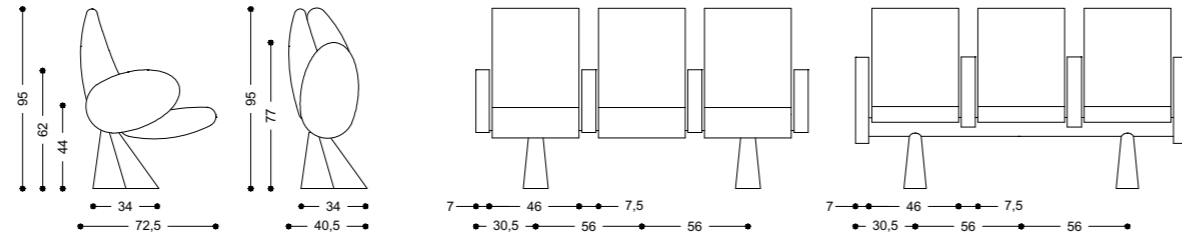

## Accessori - Accessories



Tavoletta di scrittura ribaltabile con movimento anti-panico  
Tip-up writing tablet with anti-panic movement



Elemento di identificazione fila e numerazione posto  
Row identification element and seat numbering



M100







### Design essenziale

Poltrona che si caratterizza per il design equilibrato ed essenziale, in grado di offrire configurazioni personalizzate anche per allestimenti complessi. Disponibile in più versioni, la possibilità di combinare liberamente componenti e accessori permette di soddisfare esigenze funzionali diverse.

### Comfort e compattezza

Leggermente sagomati, per accogliere in modo confortevole, schienale e sedile si compattano in modalità chiusa, rientrando perfettamente all'interno delle fiancate che sono disponibili sia con lunghezza fino a terra che corte (nella versione su barra).

### Essential design

Armchair characterized by a balanced, essential design, capable of offering customised solutions also for complex set-ups. Available in several versions, the possibility of combining components and accessories freely enables to meet different functional needs.

### Comfort and compactness

Slightly shaped to offer a comfortable seating, the backrest and seat come together when closed, fitting perfectly into the sides, which are available both in the floor-length version and in the short version on beam.





### Fiancate

Fiancate lunghe oppure corte (nella versione su barra) con struttura portante interna in acciaio e cassonetto imbottito e rivestito oppure in legno. L'installazione può avvenire su piano orizzontale, inclinato o su gradoni, in file diritte o in curva (per poltrone con fiancate a terra e con raggio minimo 8 m).

### Sides

Long or short sides (on beam version) with steel internal load-bearing structure and padded covered or wood box. Installation on flat and sloped flooring or on steps, in straight or curved rows (armchairs with floor-length sides, minimum radius 8m.)





## Sedile e schienale

Sedile e schienale con struttura in multistrato, imbottitura in poliuretano espanso indeformabile, a combustione ritardata e rivestimento in tessuto, ecopelle o pelle. Dispositivo a gravità che consente il ribaltamento del sedile con movimento ammortizzato. Schienale fornito in due angolazioni coordinate al sedile per favorire sempre una perfetta visuale, sia in platea che in galleria.

## Seat and backrest

Seat and backrest with plywood structure and fire-retardant, non-deformable expanded polyurethane padding, with fabric, eco-leather or leather covering. Gravity device allowing the seat to tilt with a cushioned movement. Backrest supplied with two different angles coordinated with the seat, to facilitate a perfect view at all times, whether in stalls or in gallery.







Sheikh Jaber Al-Ahmad Cultural Centre - Jaber Al Ali Hall  
Kuwait City, Kuwait







Finiture - Finishes



# Dimensioni - Dimensions

## M100 Standard

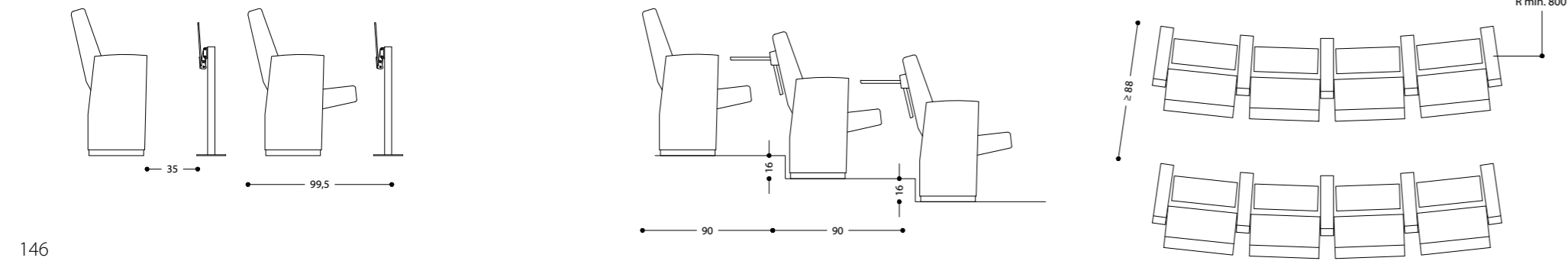
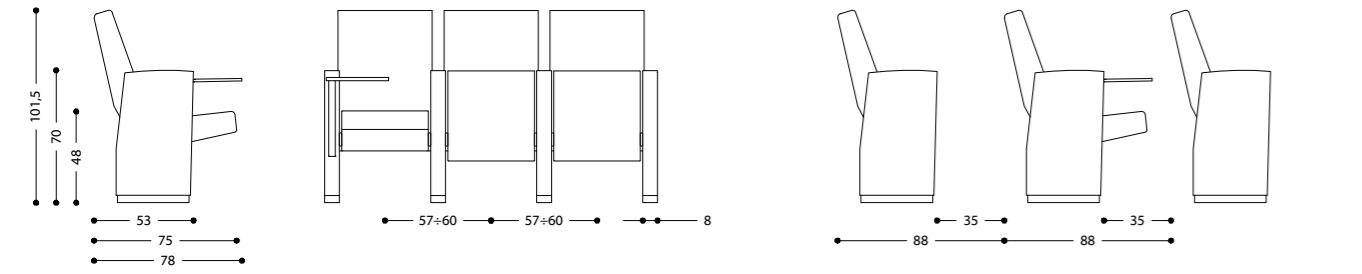
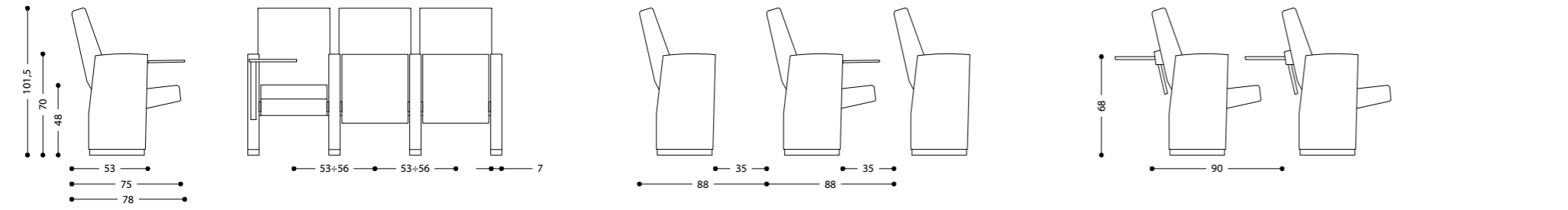

## M100 Large su base singola - M100 Large on single base

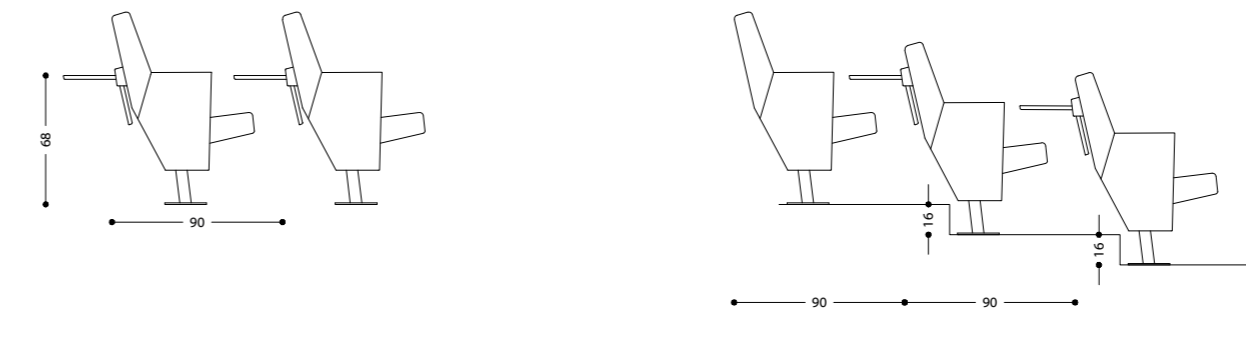
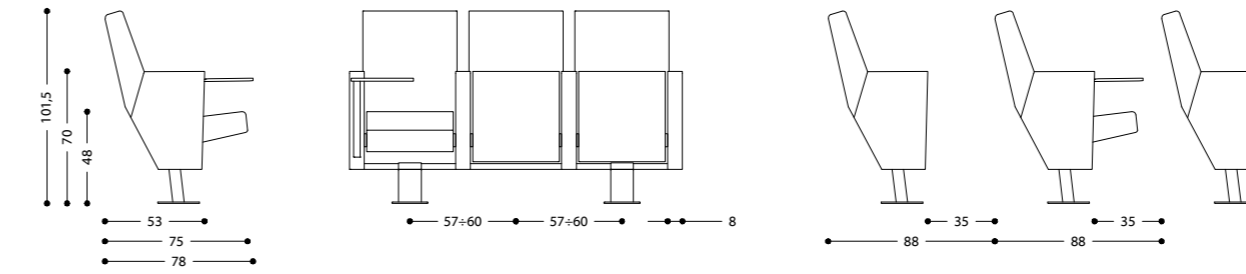
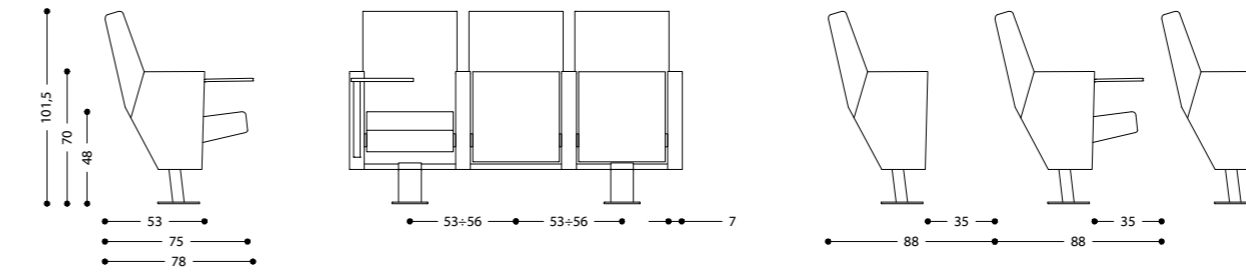



## Accessori - Accessories



Elemento di identificazione fila e numerazione posto  
Row identification element and seat numbering element

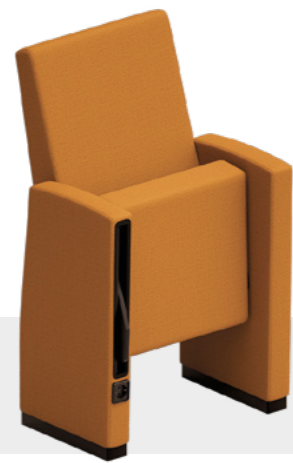

Predisposizione per l'elettrificazione (presa elettrica su richiesta)  
Provision for power supply (socket on demand)



Pannello sotto-sedile in legno verniciato  
Painted wood under seat panel



Tavoletta di scrittura ribaltabile a scomparsa  
Tip-up foldaway writing tablet



Sistema che permette l'amovibilità delle poltrone, su ruote, in caso di non utilizzo (per poltrone con piedi da fissare a pavimento in file diritte)  
Accessory system allowing the armchairs to be moved, on castors, when not in use (for armchairs with floor fixing feet, in straight rows)



Cilindro forato di aerazione per poltrona su base singola  
Perforated ventilation cylinder for beam-mounted armchair



Carter retro-schienale basso in legno verniciato  
Painted wood low backrest panel



Tavolino retro-schienale ribaltabile con movimento anti-panico  
Backrest tip-up table with anti-panic movement



Tavolino di scrittura ribaltabile su base singola mod. T200  
Tip-up writing table on single base mod. T200



# C900

Baldanzi & Novelli





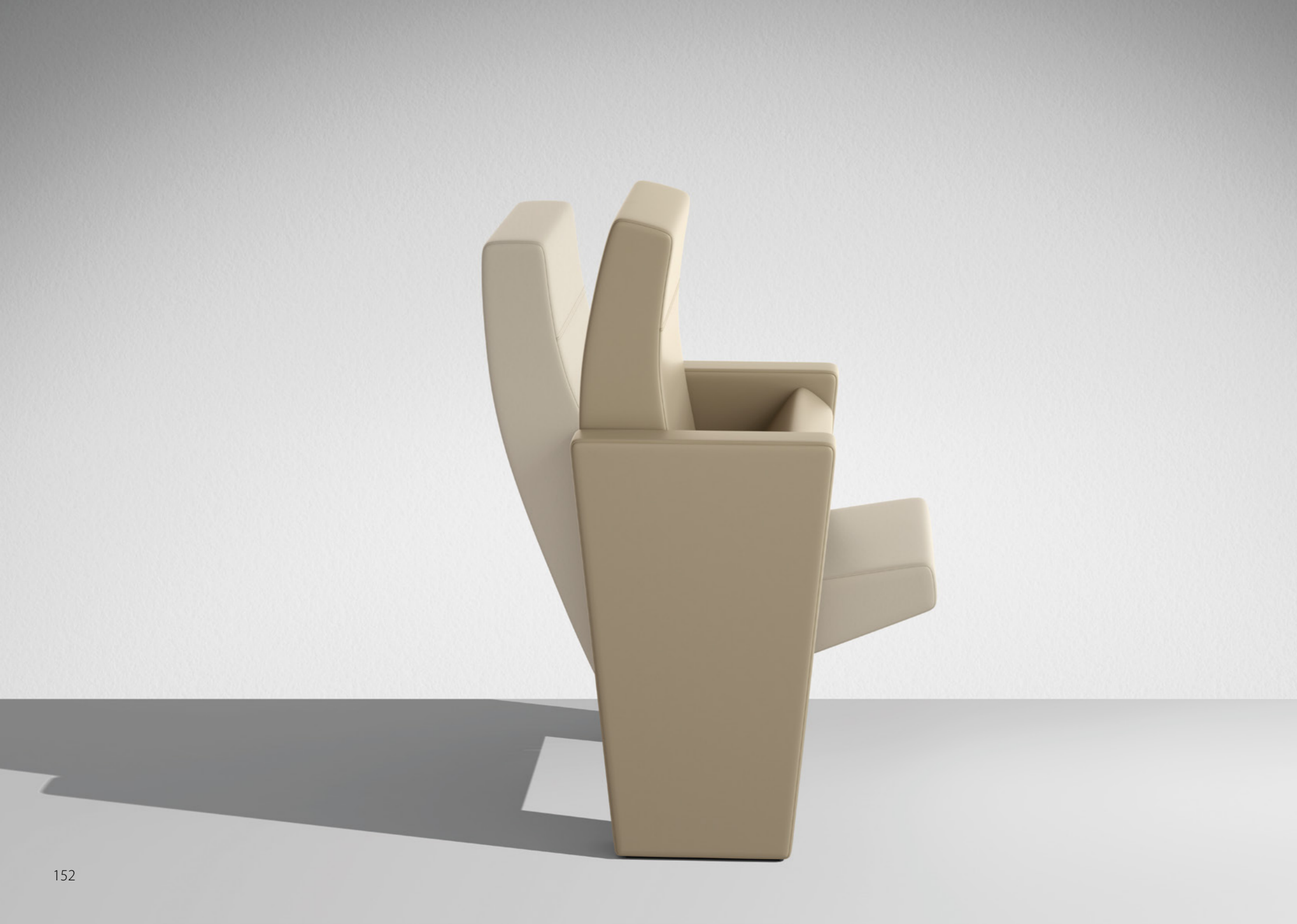

### **Sistema di chiusura sincronizzata**

Il sistema brevettato di chiusura sincronizzata di sedile e schienale Sincro Lamm accentua la compattezza della poltrona riducendone l'ingombro, in modo da consentire maggiore libertà nei movimenti e una seduta più accogliente e confortevole.

### **Comfort e design**

Poltrona che si caratterizza per l'ergonomia, la funzionalità e il comfort. Qualificata da un design rigoroso ed essenziale, presenta una linea elegante e contenuti tecnici innovativi.

### **Synchronised closing system**

The seat and back patented synchronous closure system Sincro Lamm accentuates the armchair firmness while reducing the volume so as to allow greater freedom of movement and to provide a more welcoming and comfortable seat.

### **Comfort and design**

Armchair characterised by its ergonomics, functionality and comfort. Qualified by a rigorous, essential design, it has an elegant line and innovative technical contents.



### Sedile e schienale personalizzabili

Sedile e schienale con struttura interna in multistrato e imbottitura in schiuma poliuretana sagomata indeformabile, a combustione ritardata. Retro-schienale completamente imbottito o dotato di carter basso in legno verniciato. Sedile predisposto per accogliere nella parte inferiore un pannello in legno.

### Customisable seat and backrest

Seat and backrest with plywood internal structure and fire-retardant crushproof moulded polyurethane foam padding. Backrest fully padded or supplied with a painted wood low guard. Seat designed to house a wooden panel on the underside.



### Fiancata

Fiancata con struttura interna in acciaio ricoperta da pannelli in MDF, con imbottitura in poliuretano espanso ignifugo e rivestimento in tessuto, ecopelle o pelle. Poggia-braccio imbottito oppure riportato, in legno verniciato o rivestito. Disponibile anche con tavoletta ribaltabile a scomparsa. Piedi di ancoraggio a pavimento in acciaio verniciato.

L'installazione può avvenire su piano orizzontale, inclinato o su gradoni, in file diritte o in curva.

### Side

Side with steel internal structure covered with MDF panels, padding in fire-resistant, expanded polyurethane with fabric, eco-leather or leather covering. Padded or added armrest, in painted wood or upholstered. Also available with tip-up, foldaway writing tablet. Low floor anchoring feet in painted steel. Installation on flat and sloped flooring or on steps, in straight or curved rows.











Finiture - Finishes



## Dimensioni - Dimensions

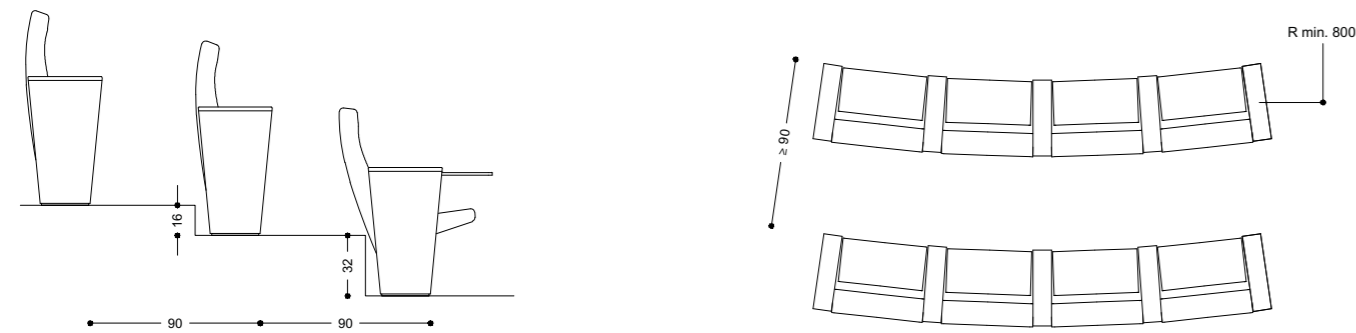
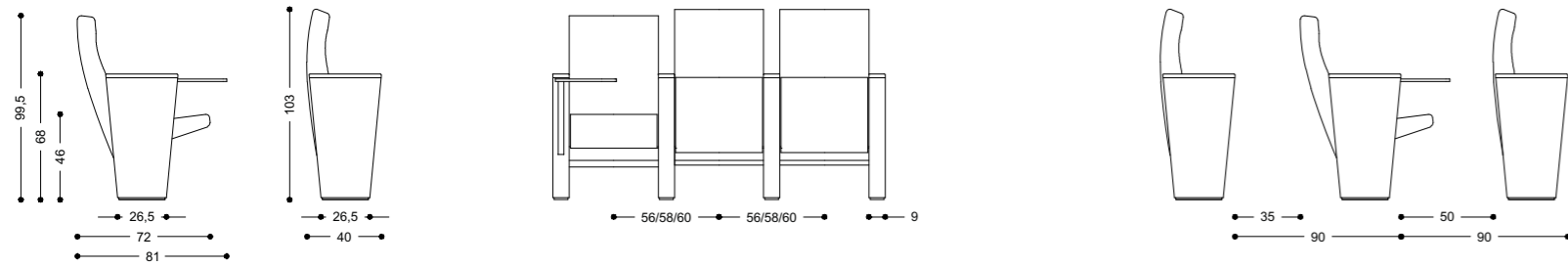

## Accessori - Accessories



Tavoletta di scrittura ribaltabile a scomparsa  
Tip-up foldaway writing tablet



Elemento di identificazione fila e numerazione posto  
Row identification and seat numbering element



Sistema che permette l'amovibilità delle poltrone, su ruote, in caso di non utilizzo  
(per poltrone con piedi da fissare a pavimento in file diritte)  
Optional system allowing armchairs to be moved away on wheels when unused  
(for armchairs with floor-fixing feet in straight rows).



Pannello sotto-sedile in legno verniciato  
Painted wood under seat panel



Predisposizione per l'elettificazione (presa elettrica su richiesta)  
Electric power supply provision (socket on demand)

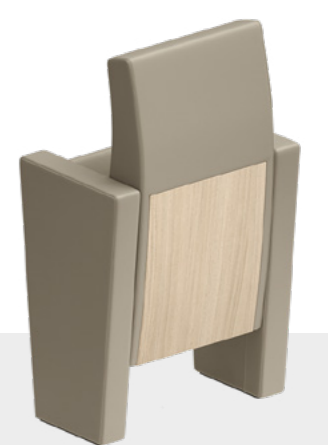

Carter retro-schienale basso in legno verniciato  
Low rear backrest panel in painted wood



# Divina







Una poltrona per teatri, auditorium e sale conferenze essenziale, ma al tempo stesso capace di garantire elevati livelli di design, comfort e flessibilità, uniti a una esaustiva gamma di accessori funzionali e d'uso.

#### Caratteristiche tecniche

L'architettura della poltrona è sviluppata per conferire una precisa identità a tutti gli elementi che la compongono: struttura, braccioli, sedile, schienale. Quest'ultimo, grazie alla particolare sagomatura nella parte di appoggio lombare, garantisce un elevato comfort di seduta. Divina è installabile con interasse variabile da 52 a 56 cm, su pavimenti in piano, inclinati o su gradoni di differente altezza e può essere configurata sia in file dritte sia curve, con raggio minimo di 8 mt. Struttura portante a vista in tubolare d'acciaio, verniciata a polveri epossipoliestere antigraffio.

This armchair is a must-have for theatres, auditoriums and conference rooms. It is highly comfortable and flexible, and boasts a superior design alongside its comprehensive range of functional and useful accessories.

#### Technical characteristics

This armchair was designed to give each element—its structure, armrests, seat and backrest—a clear identity. Thanks to the specially moulded lumbar support, the backrest provides outstanding comfort when sitting. Divina can be installed with a wheelbase that varies from 52 to 56 cm on flat or sloping floors or tiers that differ in height, and can be arranged into both straight and curved rows with a minimum radius of 8 m. Scratch-resistant steel piping coated with epoxy-polyester powder.



## Sedile e schienale

Struttura interna in multistrato e imbottitura in poliuretano espanso indeformabile, a combustione ritardata. Sedile ribaltabile a gravità, dotato di perni di rotazione e doppia piastra di supporto in acciaio. Ammortizzatori di gomma ne consentono il ribaltamento con movimento controllato e silenzioso. Schienale disponibile anche nella versione con retro portante in multistrato a vista. Rivestimenti in tessuto, ecopelle o pelle.

## Seat and backrest

Multi-layered inner part padded with non-deformable and flame-retardant polyurethane foam. Tip-up seat equipped with rotation pins and steel double support plate. Thanks to the rubber shock absorbers, it tilts silently in a controlled way. Backrest also available with visible plywood support. Upholstered in fabric, faux leather or leather.



## Fiancate

Pannelli laterali di inizio e fine fila disponibili in legno. Braccioli riportati in legno massello, nella stessa finitura delle fiancate. Le fiancate destre possono essere dotate di tavoletta di scrittura ribaltabile a scomparsa con movimento antipanico.

## Sides

Wood side panels available for the start and end of a row. Solid wood armrests with the same finish as the sides. Right sides are available with tip-up writing tablet with foldaway anti-panic movement.







Finiture - Finishes



## Dimensioni - Dimensions

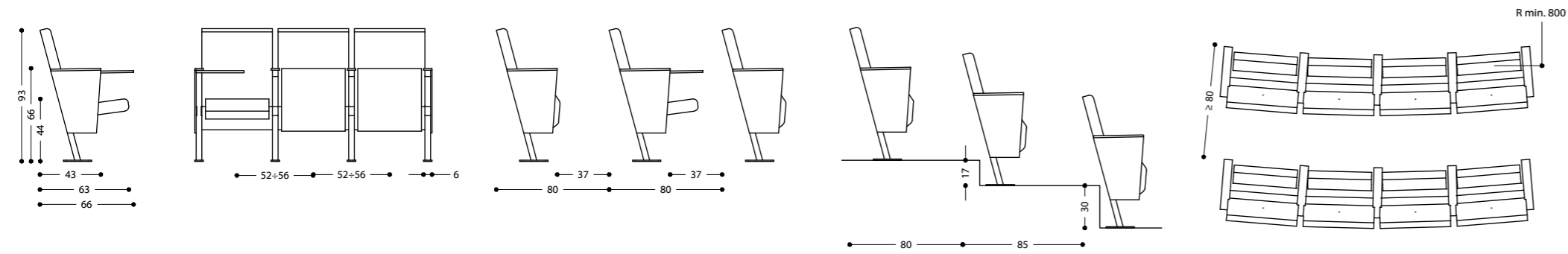

Retro-schienale in legno verniciato  
Painted wood high backrest panel

Carter retro-schienale basso in lamiera verniciata.  
Sheet metal seat back

Tavolino retro-schienale ribaltabile con movimento anti-panico  
Tip-up backrest table with anti-panic movement

## Accessori - Accessories



Elemento di identificazione fila e numerazione posto  
Row identification and seat numbering element



Tavoletta di scrittura ribaltabile a scomparsa con movimento antipanico  
Tip-up foldaway writing tablet



Pannello sotto-sedile in legno verniciato  
Painted wood under seat panel



Sistema che permette l'amovibilità delle poltrone, su ruote, in caso di non utilizzo.  
Accessory system allowing the armchairs to be moved, on castors, when not in use (for armchairs with floor fixing feet, in straight rows)



# Sipario

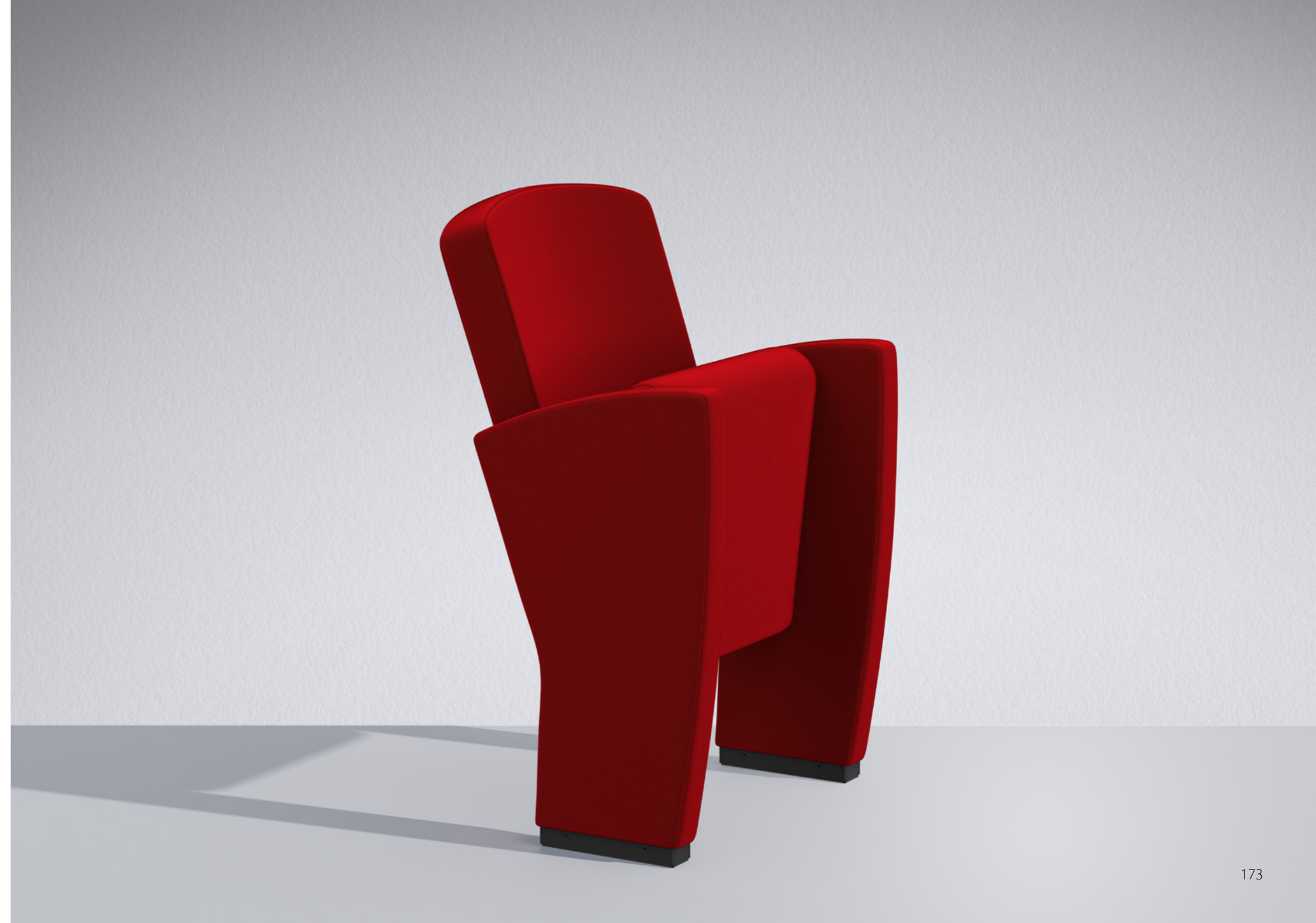





### Storia e innovazione

Un grande classico completamente rivisitato torna a far parte della proposta produttiva Lamm. Oltre ad un'infinita serie di migliorie tecnico/costruttive la poltrona è stata arricchita di numerose versioni e varianti per soddisfare il più ampio spettro di esigenze progettuali di teatri, auditorium e sale conferenze.

### History and innovation

This absolute classic has been revamped and rejoins Lamm's product range. As well the infinite number of technical/structural improvements made, this armchair has expanded with a number of versions and varieties that will satisfy a whole host of design requirements for theatres, auditoriums and conference halls.

### Design e tecnologia

Lo stile sobrio, i rivestimenti, le finiture, le tecnologie costruttive, la caratterizzano come seduta di grande prestigio. Accogliente e molto confortevole offre grandi possibilità di personalizzazione, sia nel design che nei materiali e negli accessori.

### Design and technology

The understated style, upholstery, finishes and manufacturing technologies employed make this a high-quality chair. Pleasant and very comfy, it can be customised in all kinds of ways, both in terms of design and materials and accessories.





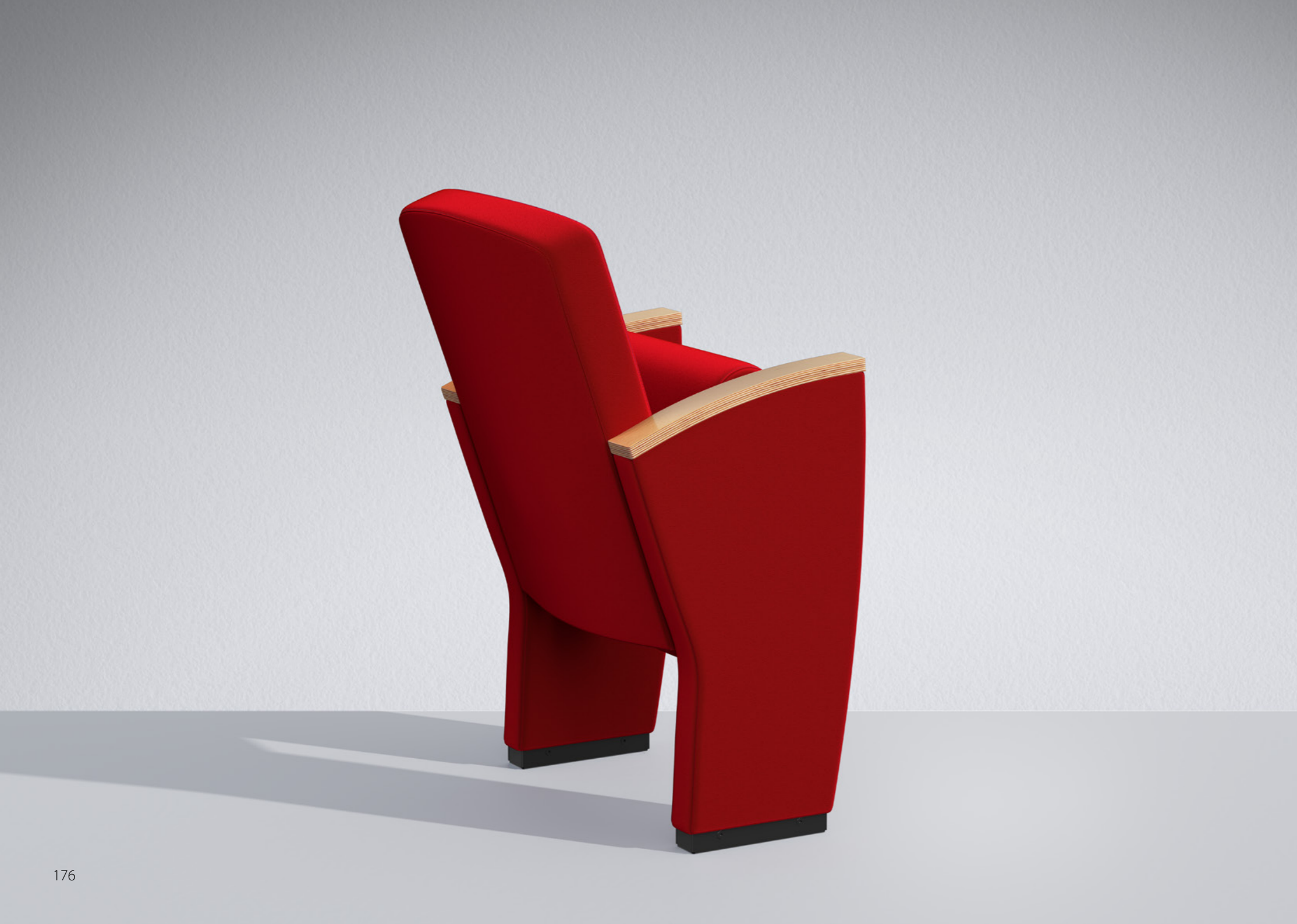

### Sedile e schienale

Completamente rivestiti in tessuto, ecopelle o pelle, hanno struttura interna in multistrato imbottita con poliuretano espanso indeformabile a combustione ritardata. Due diverse inclinazioni dello schienale assicurano la perfetta visuale in platea e in galleria. Per la versione Standard è inoltre disponibile lo schienale tondo. Il sedile, ribaltabile per gravità, è dotato di perni di rotazione in acciaio ancorati alla struttura.

### Seat and backrest

Fully upholstered in fabric, faux leather or leather, these have a multi-layered inner part padded with non-deformable and flame-retardant polyurethane foam. Two different types of backrest ensure that spectators have the perfect view from the stalls and gallery. For the Standard version, a curved backrest is also available. The seat, with gravity-driven tip-up mechanism, features steel hinge pins fixed to the structure.



## Fiancate

Imbottite con rivestimento in tessuto, ecopelle o pelle, oppure con finitura in legno a vista, hanno struttura portante interna in acciaio, corredata di blocco in alluminio per l'inserimento dei perni di rotazione e di sostegno del sedile. Possono inoltre essere applicati braccioli imbottiti o in legno verniciato. Ancoraggio a pavimento con piede in lamiera stampata o in versione su barra da 2-3 posti in tubolare d'acciaio. Entrambe verniciate a polveri epossipoliestere antigraffio. Nella versione su trave le fiancate sono disponibili con pannelli laterali che poggiano sulla barra, mentre le fiancate di inizio e fine fila arrivano a terra.

## Sides

Padded and upholstered in fabric, faux leather or leather, or complete with a visible wood finish, these have a steel load-bearing inner structure equipped with an aluminium block for inserting the seat's hinge and support pins. They can also be fitted with padded or painted-wood armrests. Fixed to the floor with pressed sheet-metal feet, or with steel tubes for the beam-mounted 2-3 seat version. Both coated with anti-scratch epoxy-polyester powders. With the beam-mounted version, sides are available with side panels that rest on the beam, while the side parts at either end of the row reach down to the floor.

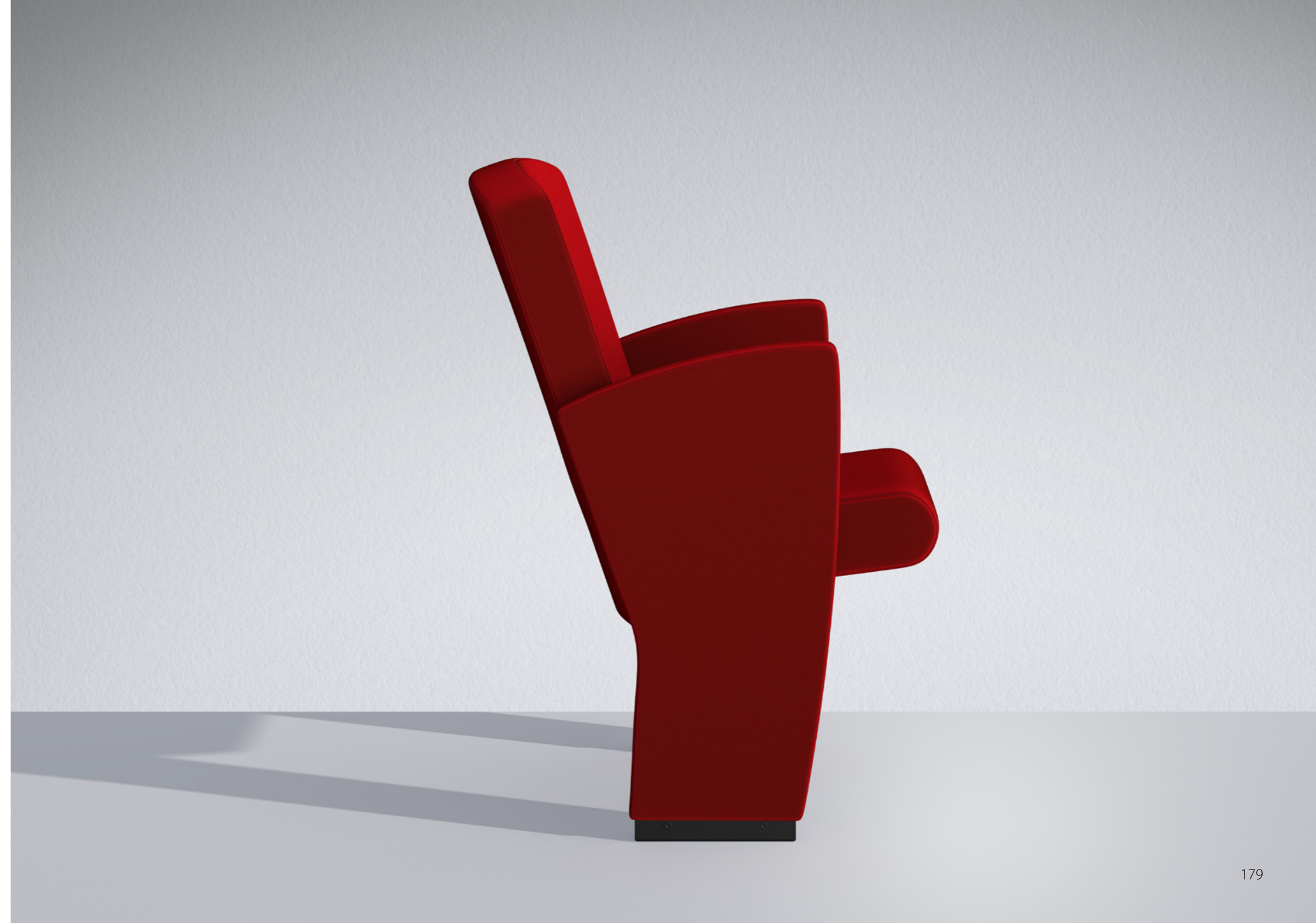



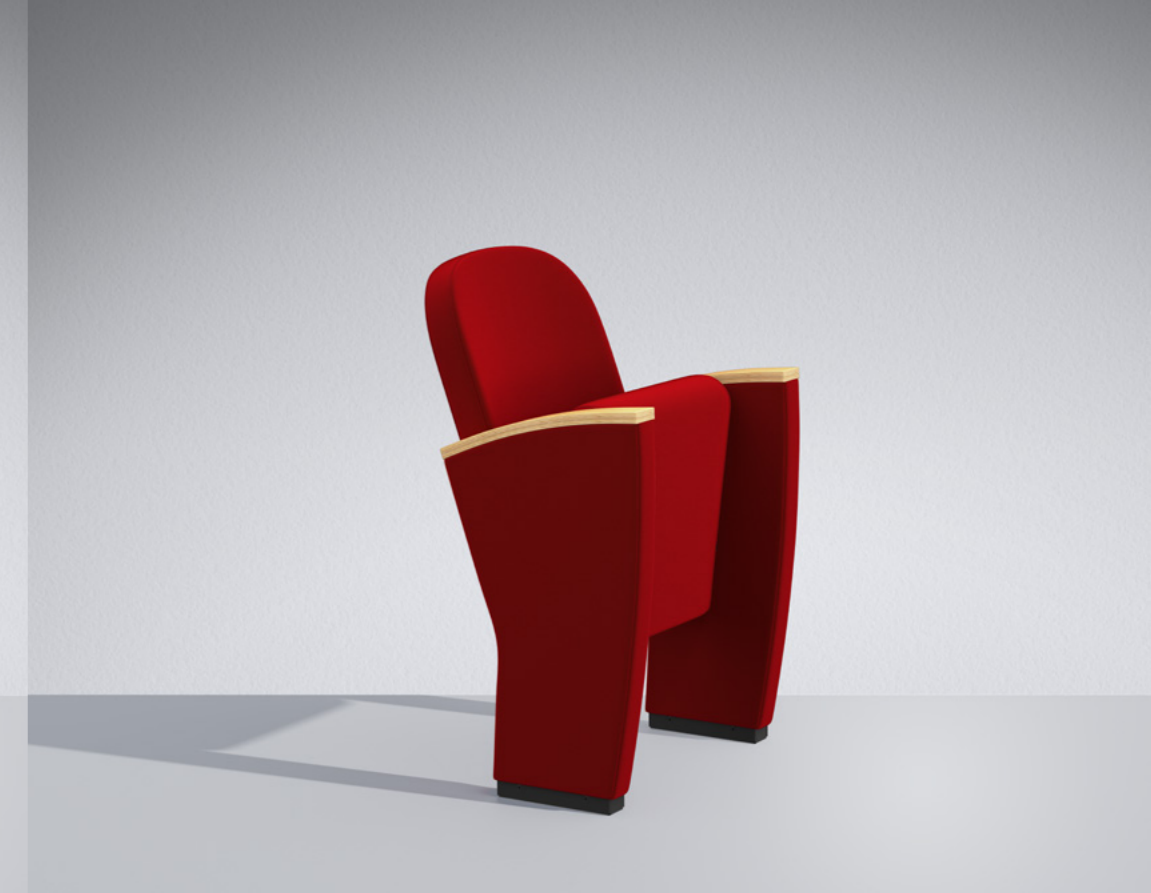
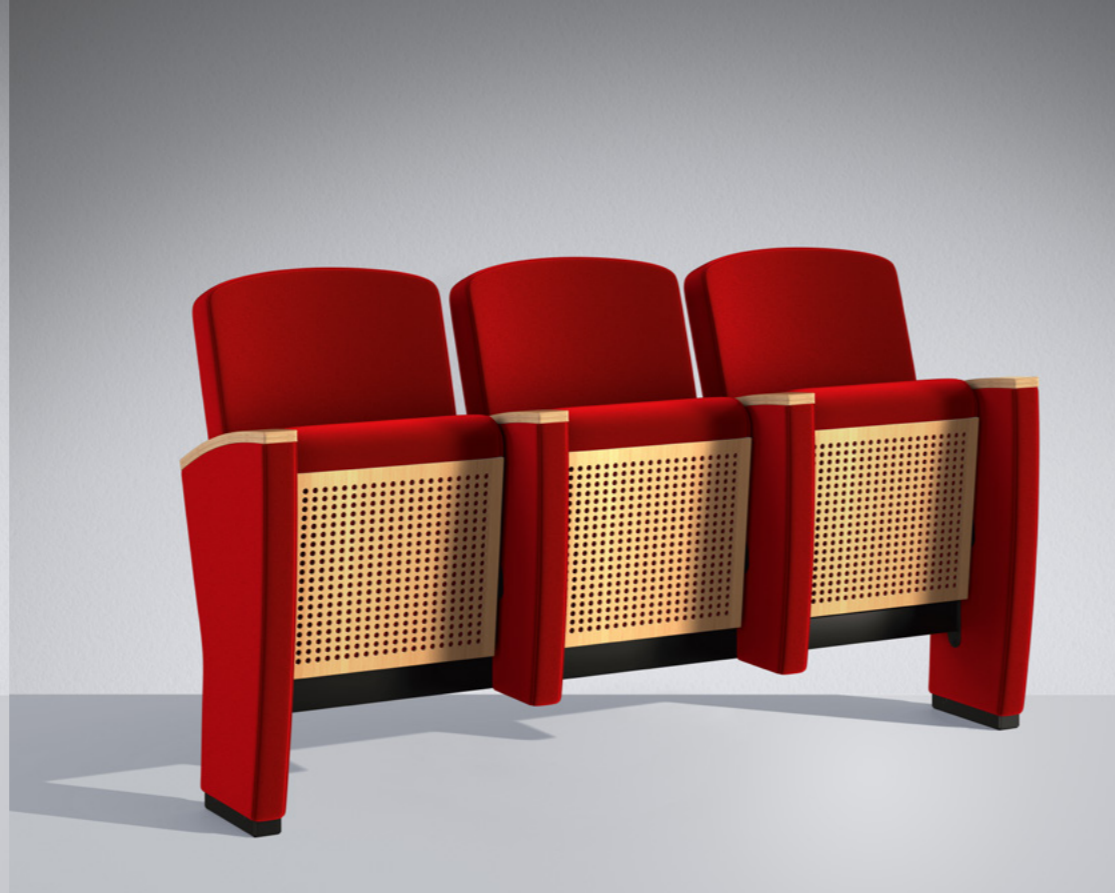

## Tipologie

Offerta nella versione "Standard" o "Large" con schienale maggiorato e fiancata più larga. Tutte le versioni sono disponibili con fiancate a terra oppure su barra da 2-3 posti collegabili in file. È possibile l'installazione su piani orizzontali, inclinati o su gradoni, in file diritte oppure in curva per poltrone con fiancate a terra e con raggio minimo 8 mt.

## Versions

Available in "Standard" or "Large" with a larger backrest and wider side part. All versions are available with sides reaching down to the floor, or set on a beam with 2-3 seats that link together in a row. They can be installed on horizontal, sloped or inclined floors in straight rows, or curved rows for armchairs with sides reaching down to the floor (minimum radius of 8 metres).









Finiture - Finishes



## Dimensioni - Dimensions

### Sipario Standard

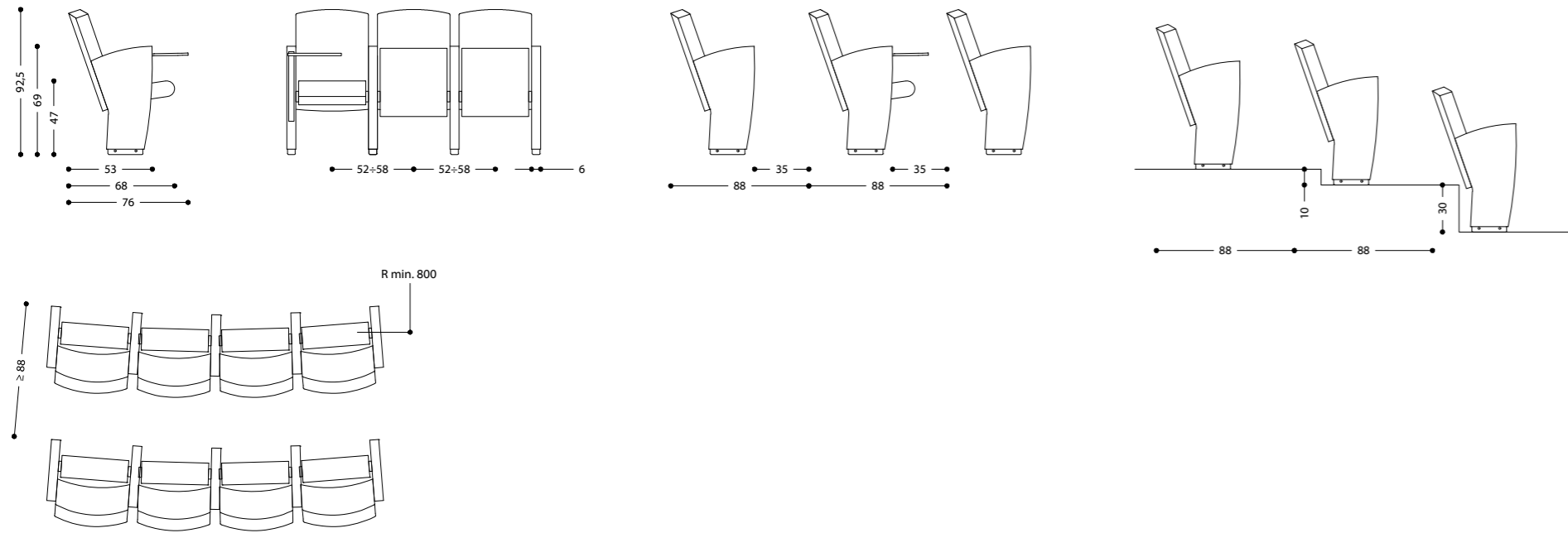

### Sipario Standard on beam

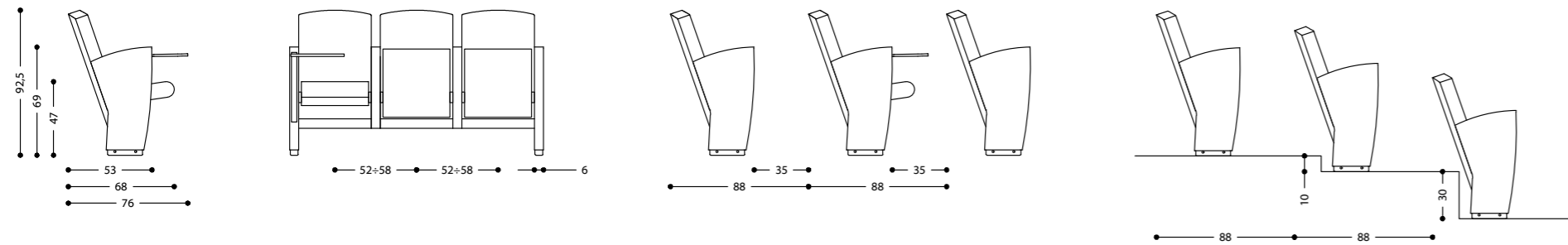

### Sipario Large

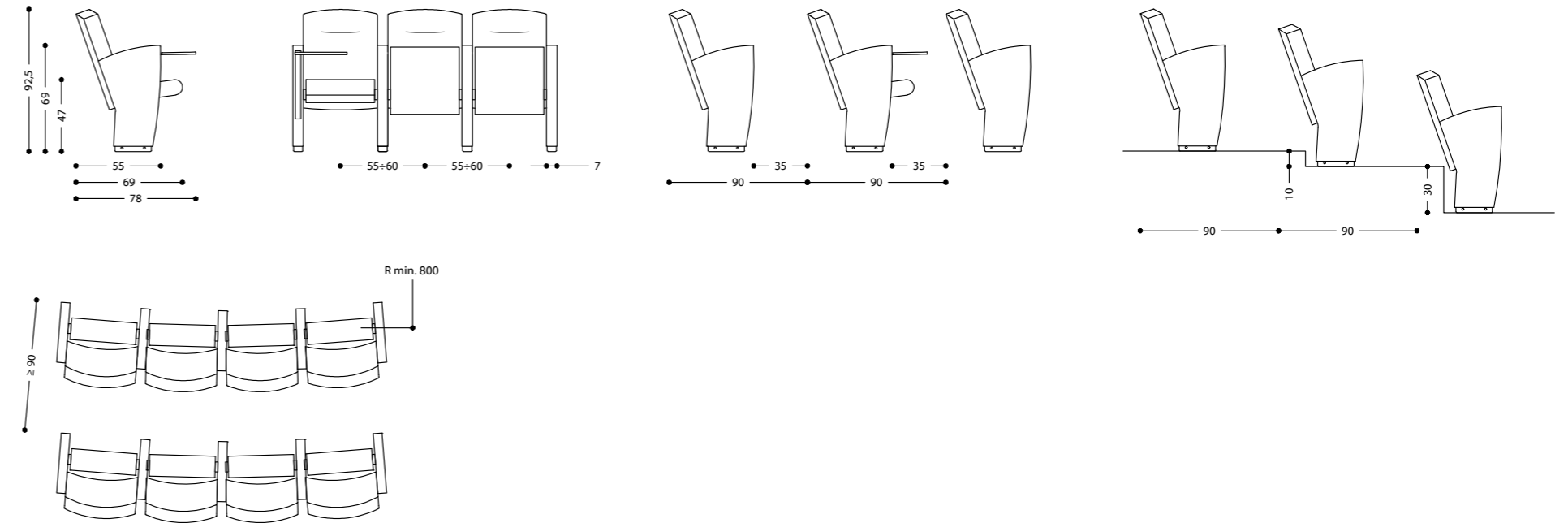

### Sipario Large on beam

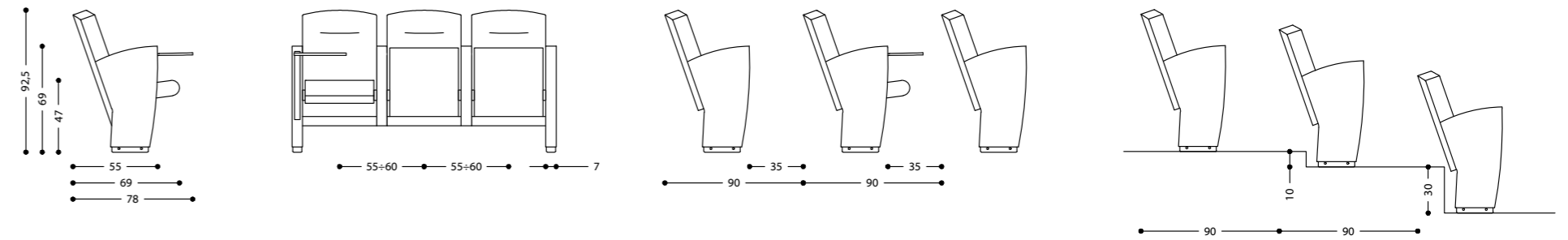



## Accessori - Accessories



Elemento di identificazione fila e numerazione posto  
Row identification element and seat numbering



Predisposizione per l'elettrificazione per poltrone mod. Large  
(presa elettrica su richiesta)  
Provision for electric power supply for armchairs mod. Large  
(socket on demand)



Pannello sotto-sedile in legno verniciato  
Painted wood under seat panel



Tavoletta di scrittura ribaltabile a scomparsa  
Tip-up foldaway writing tablet



Carter retro-schienale basso in legno verniciato  
Painted wood low backrest panel



Retro-schienale alto in legno verniciato  
Painted wood high backrest panel



Sistema che permette l'amovibilità delle poltrone, su ruote, in caso di non utilizzo  
Accessory system allowing the armchairs to be moved, on castors, when not in use



Predisposizione per l'elettrificazione per poltrone mod. Standard  
(presa elettrica su richiesta)  
Provision for electric power supply for armchairs mod. Large  
(socket on demand)



Unica







### Sedile e schienale

Sedile e schienale con struttura interna in tubolare di acciaio e imbottitura in poliuretano espanso, schiumato a freddo, a combustione ritardata, con cinghie elastiche ad elevata resistenza. Sedile con dispositivo a gravità che ne consente il ribaltamento con movimento ammortizzato. Schienale, alto e basso, con inclinazione diversificata per una perfetta visuale, sia in platea che in galleria.

### Seat and backrest

Seat and backrest with tubular steel internal structure and fire-retardant cold-foamed expanded polyurethane padding, provided with high-resistance elastic belts. Gravity device allowing the seat to tilt with a cushioned movement. High and low backrest with variable inclination for a perfect view at all times, whether in stalls or in gallery.





### Fiancate

Fiancata con struttura portante interna in metallo nascosta da cassonetto in multistrato, imbottitura in poliuretano espanso indeformabile a combustione ritardata, disponibile completamente rivestita in pelle o tessuto oppure in legno. Poggia-braccio in diverse varianti: riportato rivestito, riportato in poliuretano integrale o in legno. Piede di ancoraggio a pavimento in lamiera con collarino di copertura verniciato. L'installazione può avvenire su piano orizzontale, inclinato o su gradoni, in file diritte o in curva.



### Sides

Side with metal internal load-bearing structure hidden into a plywood box with fire-retardant, non-deformable expanded polyurethane padding, fully covered available with leather, fabric or in wood. Various versions of armrest: added and covered armrest, added armrest in integral polyurethane or in wood. Sheet metal floor anchoring foot with painted protective collar. Installation on flat and sloped flooring or on steps, in straight or curved rows.





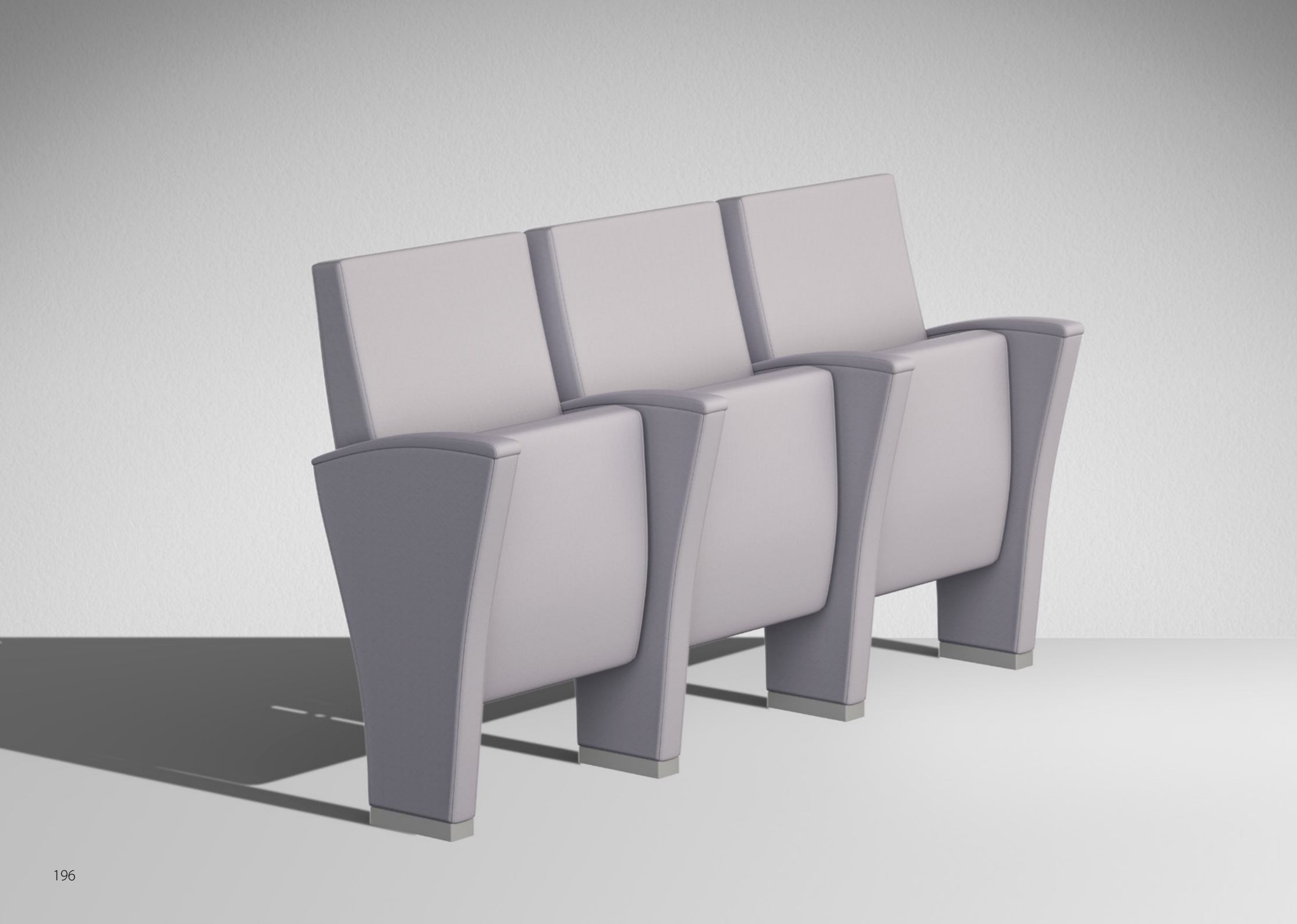

#### **Adattabilità e comfort**

Poltrona che si contraddistingue per il comfort e la flessibilità di installazione, associati a un design di facile adattabilità ai più differenziati contesti applicativi.

#### **Adaptability and comfort**

Armchair characterized by its comfort and flexibility of installation, associated with a design that adapts easily to a wide range of applications.









Finiture - Finishes



## Dimensioni - Dimensions

Unica schienale basso - Unica with low backrest

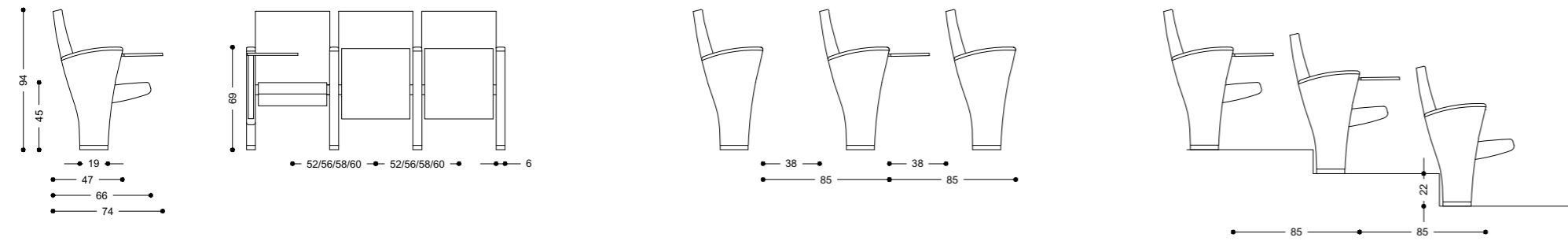

Unica schienale alto - Unica with high backrest

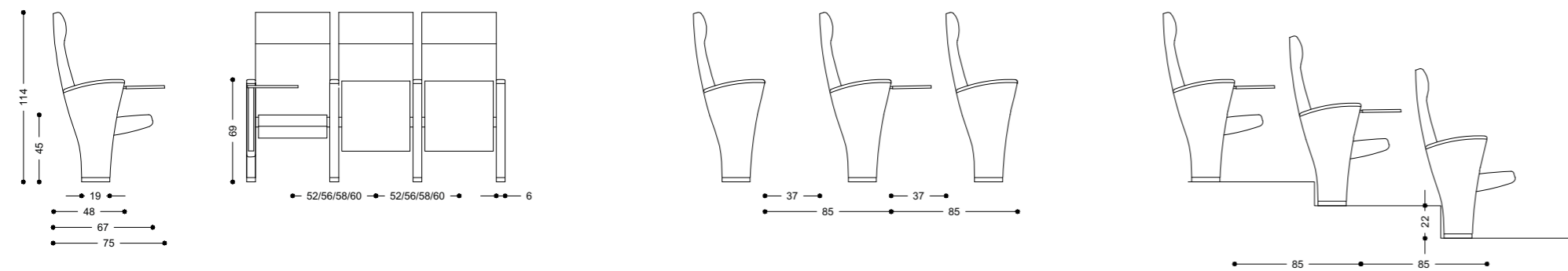

Unica schienale basso e alto - Unica with low and high backrest

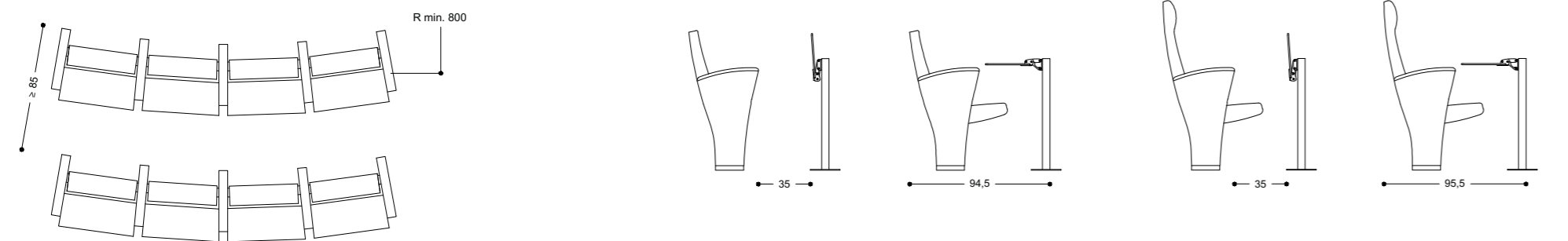

## Accessori - Accessories



Tavoletta di scrittura ribaltabile con movimento anti-panico  
Tip-up foldaway writing tablet with anti-panic movement

Elemento di identificazione fila e numerazione posto  
Row identification element and seat numbering element

Pannello sotto-sedile in legno verniciato  
Painted wood under seat panel



Carter retro-schienale basso in legno verniciato  
Painted wood low backrest panel

Sistema che permette l'amovibilità delle poltrone, su ruote, in caso di non utilizzo  
(per poltrone con piedi da fissare a pavimento in file diritte)  
Accessory system allowing the armchairs to be moved, on castors, when not in use  
(for armchairs with floor fixing feet, in straight rows)

Tavolino di scrittura ribaltabile su base singola mod. T200  
Tip-up writing table on single base mod. T200



Futura







### Immagine tecnologica

Poltrona su trave ideale per grandi ambienti caratterizzata da una forma molto compatta, una struttura resistente e una tecnologia nei movimenti che permette il suo utilizzo abbinato ai sistemi a scomparsa.

### Technological image

Beam-mounted armchair, ideal for large venues, characterized by a very compact shape, a strong structure and a movement technology that allows it to be used in combination with foldaway systems.



### Ingombro minimo

Dispositivo a gravità che, liberando il sedile, ne consente il ribaltamento con movimento ammortizzato. In sincrono, lo schienale si abbassa e verticalizza insieme ai braccioli riducendo le dimensioni di ingombro a soli 19 cm in fase di riposo.

### Small dimensions

Gravity system which releases and tips up the seat with a cushioned movement. The backrest lowers and at the same time moves into a vertical position in sync with the arms, reducing the armchair overall dimensions of only 19 cm when closed.







### Struttura e componenti

Trave strutturale in tubolare di acciaio verniciato e fiancata portante in alluminio pressofuso. Sedile e schienale in multistrato con imbottitura in poliuretano espanso, schiumato a freddo, a combustione ritardata. Bracciolo in legno massello o in poliuretano integrale. Disponibile con piede in appoggio antiribaltamento con registri o con piede per fissaggio a pavimento. L'installazione può avvenire su piano orizzontale, inclinato o su gradoni, in file diritte.

### Structure and components

Painted tubular steel structural beam and die-cast aluminium load-bearing side. Plywood seat and backrest with flame-retardant, cold-moulded, expanded polyurethane foam padding. Solid wood or integral polyurethane arm. Available with anti-tilt support foot with registers or with floor fixing foot. Installation on horizontal and sloped flooring or on steps, in straight rows.





### Sistema a scomparsa

Installabile con gli innovativi sistemi a scomparsa *Floor Technology* nella versione su tribune telescopiche o su binario.

### Foldaway system

It can be installed with the innovative *Floor Technology* foldaway systems, in telescopic grandstand or rail mounted version.







Finiture - Finishes



## Dimensioni - Dimensions

### Futura

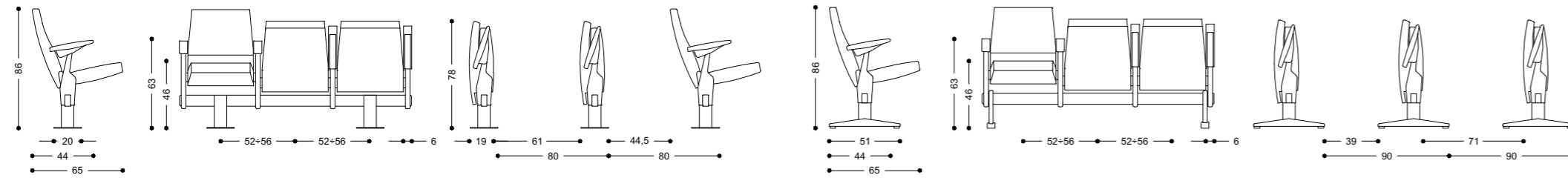

### Futura con tavoletta - Futura with writing tablet

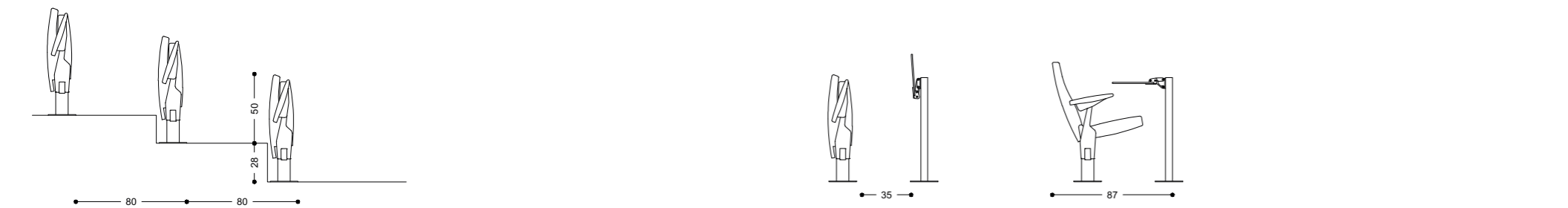
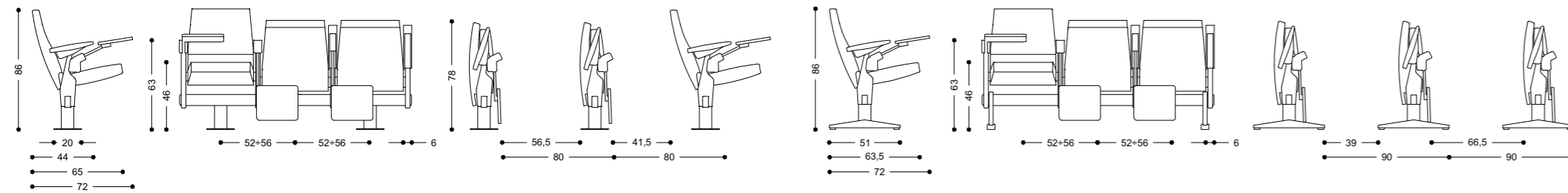

## Accessori - Accessories



Elemento di identificazione fila e numerazione posto  
Row identification element and seat numbering elements

Pannello sotto-sedile in legno verniciato  
Painted wood under seat panel

Piede anti-ribaltamento con registri  
Anti-tilt foot with registers



Pannello retro-schienale alto in legno verniciato  
Painted wood high backrest panel

Tavoletta di scrittura ribaltabile con movimento anti-panico  
Tip-up writing tablet with anti-panic movement

Tavolino di scrittura ribaltabile su base singola mod. T200  
Tip-up writing table on single base mod. T200



# Tail

Favaretto & Partners







### **Estetica dello schienale**

Teatri e auditorium hanno generalmente l'ingresso dal lato opposto a quello del palco, per cui la vista principale che lo spettatore si trova entrando mette in evidenza la parte posteriore delle sedute che diventa così l'elemento esteticamente identificativo della poltrona.

### **Eleganza e comfort**

Prodotto esclusivo di fattura artigianale: forte connotazione classica, interpretata attraverso un linguaggio contemporaneo; dettagli risolti con eleganza e sobrietà; forma avvolgente che garantisce elevati livelli di comfort e benessere.

### **Backrest aesthetics**

Theatres and auditoriums generally have their entrance from the opposite side to the stage, so that the main view seen by spectators while entering highlights the rear of the seats, which thus become the armchair defining aesthetic feature.

### **Elegance and comfort**

An exclusive hand-crafted product: a strong classical feel, interpreted using a modern style; details handled with elegance and sobriety; the wrap-around shape guarantees high levels of comfort and well-being.



### Struttura adattabile

Sedile, schienale e fiancata con struttura interna in multistrato curvato, imbottitura schienale in poliuretano espanso schiumato a freddo ignifugo con supporto lombare e rivestimenti in pelle o tessuto. Sedile con chiusura silenziata ammortizzata. Fiancate ancorate a pavimento mediante un innovativo dispositivo di fissaggio che utilizza una lamiera di acciaio integrata nella struttura (non a vista).

L'installazione può avvenire su piano orizzontale, inclinato o su gradoni, in file diritte o in curva.



### Adaptable structure

Seat, back and side with curved plywood internal structure, backrest padding in flame-retardant, cold-foamed expanded polyurethane, with lumbar support and leather or fabric covering. Seat with silenced, cushioned closing system.

Sides anchored to the floor by means of an innovative fixing device using a steel plate integrated in the structure (not visible). Installation on horizontal and sloped flooring or on steps, in straight or curved rows.





Dimensioni - Dimensions

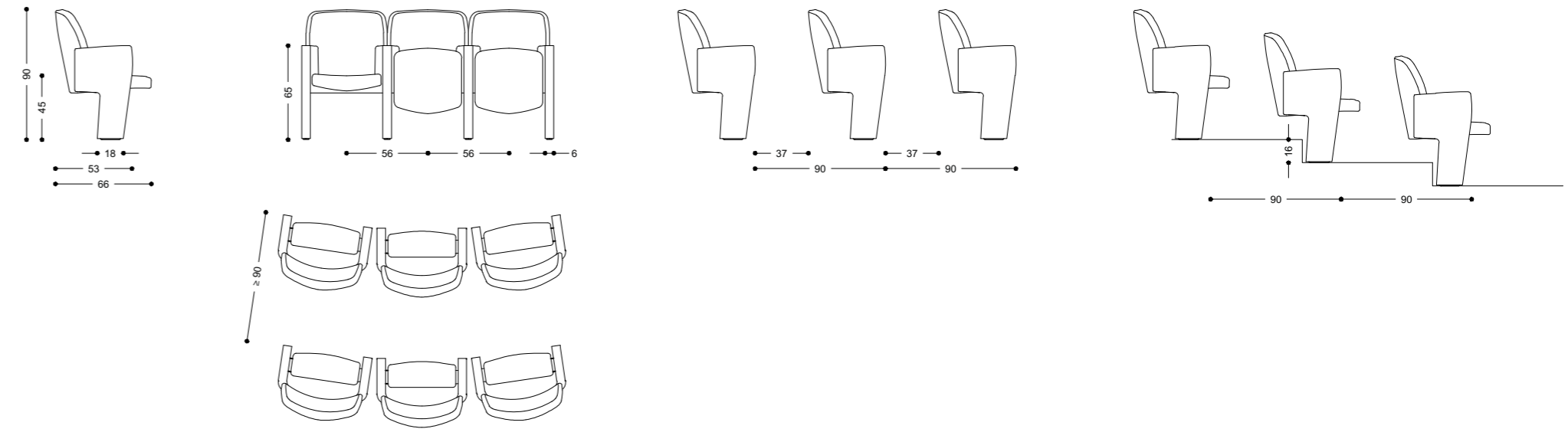

Accessori - Accessories



Elemento di identificazione fila e numerazione posto  
Row identification element and seat numbering element



Retro-schienale in legno verniciato  
Painted wood backrest panel



Star







### Forma e funzione

Sistema di poltrone con fiancate a terra dotate di grande flessibilità applicativa che, attraverso un design senza compromessi, esprimono dal primo impatto i loro contenuti di elevato comfort ed ergonomia, finalizzati a soddisfare le esigenze di aree relax di prestigio, sale home theatre e aree vip di auditorium, cinema e stadi. La forma ergonomica dello schienale, ottenuta grazie all'imbottitura realizzata in 3 differenti sezioni, garantisce il massimo comfort di seduta in tutte le posizioni anche per lunghi periodi di utilizzo.

### Sedile, schienale e poggiatesta

Sono realizzati con struttura interna in multistrato e imbottitura in poliuretano espanso indeformabile, a combustione ritardata. Rivestimento in tessuto, pelle o eco-pelle. Nella versione reclinabile, l'inclinazione dello schienale e del poggiatesta è regolata da 2 motori elettrici attivati mediante un controller a infrarossi o in alternativa da un'apposita tastiera inserita nella fiancata della poltrona. La movimentazione di schienale e poggiatesta può avvenire in sincrono o essere indipendente.

### Shape and function

Highly flexible in terms of application, these armchairs with sides reaching down to the floor are, thanks to their uncompromising design, immediately striking due to their outstanding comfort and ergonomics designed to meet the needs of luxury relaxation areas, home theatres, and VIP suites in auditoriums, cinemas and stadiums. The ergonomic shape of the backrest, provided by the 3 padded parts, provides the utmost comfort in any sitting position, even when the chair is used for long periods of time.

### Seat, backrest and footrest

These feature a multi-layered inner part padded with non-deformable and flame-retardant polyurethane foam. Upholstered in fabric, faux leather or leather. With the reclining version, the inclination of the backrest and footrest is regulated by 2 electric motors activated by an infrared controller or, alternatively, by a keypad embedded in the side of the armchair. The backrest and footrest can be moved together at the same time or independently.



### Fiancate

Completamente rivestite, racchiudono una struttura in multistrato. Nella versione fissa svolgono funzione portante e sono predisposte per accogliere le piastre in acciaio per il fissaggio dello schienale e il sostegno del sedile. Piedini di appoggio a pavimento regolabili in termoplastica nera.

### Poltrone reclinabili

Dotate di struttura interna portante in tubolare d'acciaio predisposta per il fissaggio delle fiancate e il sostegno del sedile. Alla stessa sono direttamente fissati lo schienale e il poggiatesta, per consentirne la movimentazione e regolazione.

### Sides

Fully upholstered, these have a multi-layered inner part. With the fixed version, the side parts are load-bearing and designed to accommodate the steel plates used to fix the backrest and seat support in place. Supported by adjustable, black thermoplastic feet at the bottom.

### Reclining armchairs

These have load-bearing steel pipes inside. The structure is designed so that the side parts and seat support can be attached. The backrest and footrest are attached directly, allowing you to move and adjust the chair.







## Tipologie

L'offerta prevede poltrone fisse in versione singola, con doppia fiancata. Poltrone collegabili in file, con fiancata in condivisione. Poltrone singole reclinabili. L'installazione è in appoggio a pavimento su piani orizzontali o gradoni, in file diritte.

## Versions

Varieties on offer include fixed, double-sided individual armchairs. Armchairs that link together in a row and share side parts. Individual reclining armchairs. They are installed in straight lines on horizontal or inclined floors.



## Finiture - Finishes

## Dimensioni - Dimensions

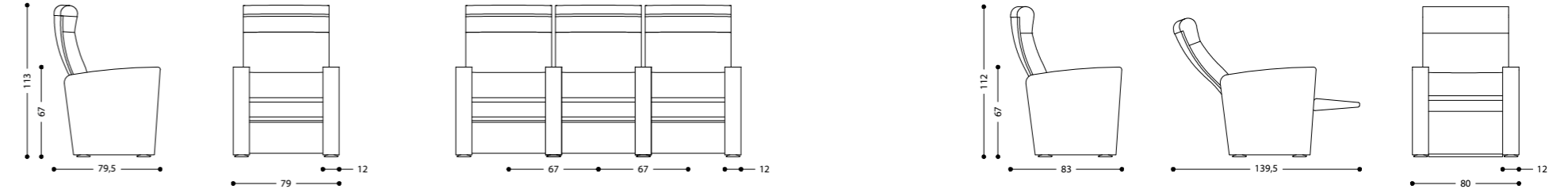

## Optional



Schienale rivestito in pelle con rombi cuciti  
Rhombus stitched on the back of the armchair

## Accessori - Accessories



Porta bicchiere  
Cup holder



Telecomando senza fili per movimentare lo schienale e il poggiatesta  
Wireless remote control used to move the backrest and footrest



Tastiera di controllo inclinazione schienale e poggiatesta inserita nella fiancata  
Keypad embedded in the side which controls the inclination of the backrest and footrest



# On Time

Baldanzi & Novelli







### Struttura e componenti

Sedile, schienale e fiancate con struttura interna in acciaio e imbottitura in poliuretano espanso indeformabile schiumato a freddo a ritardata combustione.

Sedile provvisto di cinghie elastiche a elevata resistenza.

Schienale dotato di un particolare dispositivo a molle in acciaio armonico che rende la parte superiore più flessibile e confortevole adattando l'inclinazione alla posizione della schiena.

Fiancate fino a terra, disponibili con piedi fissi, su ruote piroettanti, di colore nero.

### Structure and components

Seat, backrest and sides with steel internal structure and flame-retardant, cold-moulded, non-deformable expanded polyurethane foam padding.

Seat with high resistance elastic belts.

Backrest fitted with harmonic steel springs that make its upper part more flexible and comfortable, and accompany every movement of the back through an adjustable inclination.

Floor-length sides, available with fixed feet, swivelling or double castors, in black.





### Innovazione e funzionalità

Poltrona di nuova concezione per ambienti polifunzionali, caratterizzata da un esclusivo sistema di movimenti che, pur mantenendo elevati livelli di comfort, permettono a sedile e fiancate di ripiegarsi in sovrapposizione sullo schienale riducendo lo spessore complessivo a soli 20 cm, per essere facilmente spostata e conservata dopo l'utilizzo.

### Innovation and functionality

New concept armchair for multi-purpose spaces, characterised by an exclusive movement system that, whilst maintaining high levels of comfort, allows seat and sides to fold up on the backrest, thus reducing its size to only 20 cm., to be easily moved when not in use.





### **Finiture**

Rivestimenti in tessuto, ecopelle o pelle, in un'ampia gamma di colori.  
Finitura superiore e inferiore delle fiancate in termoplastica nera.

### **Finishes**

Coverings in fabric, eco-leather or leather in a full range of colours.  
Side upper and lower finish in black thermoplastic.









Finiture - Finishes



## Dimensioni - Dimensions

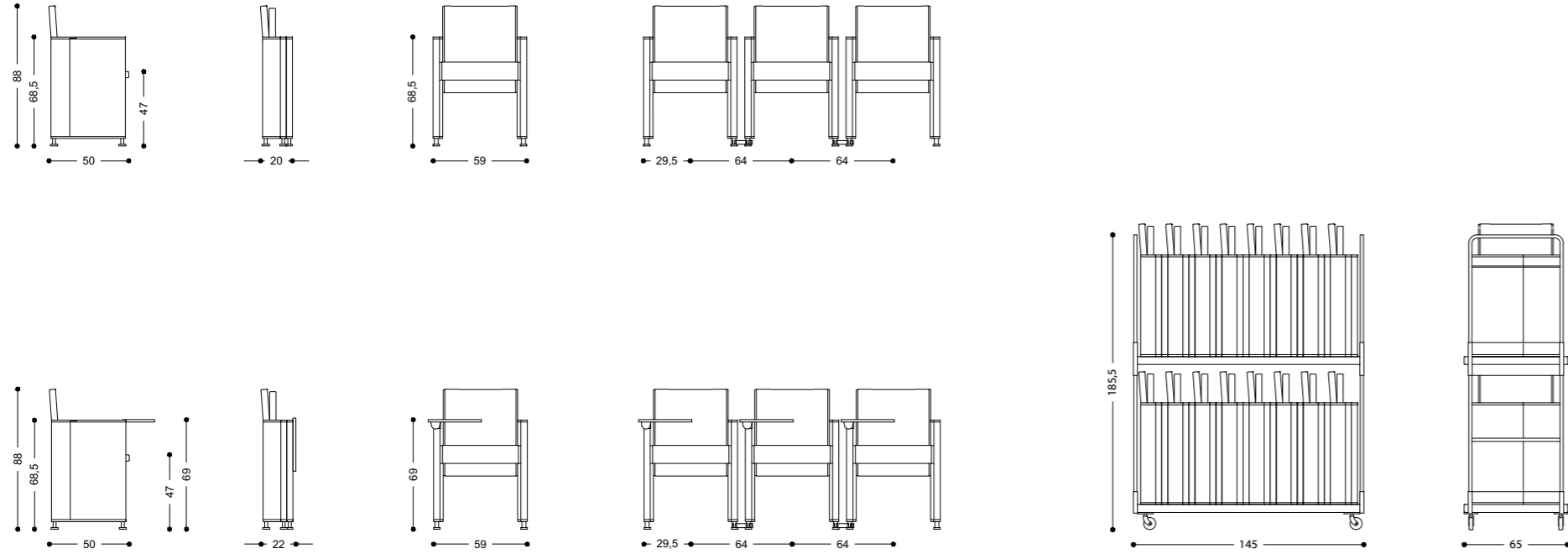

## Accessori - Accessories



Tavoletta di scrittura ribaltabile con movimento antipánico, agevolmente applicabile alla fiancata ed estraibile a incastro (senza l'utilizzo di viti), per facilitare le operazioni di accatastabilità.  
Tip-up writing tablet with anti-panic movement, easily applicable to the side with extractable interlocking system (no screws used), to facilitate storage operations.



Ganci di allineamento in nylon (solo per piedi fissi).  
Nylon connecting hooks (only for fixed feet).

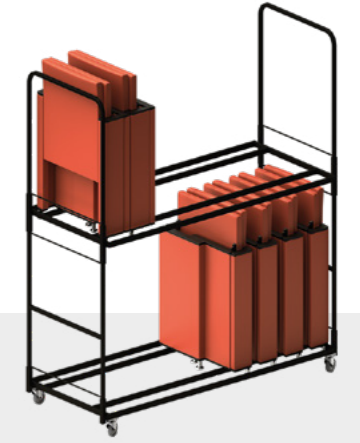

Carrello per il trasporto delle poltrone chiuse.  
Dolly for moving closed armchairs.

## Ruote e piedini - Castors and glides



Piedini fissi in nylon  
Fixed feet in nylon

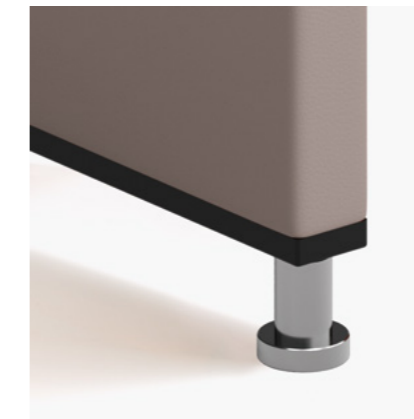

Piedini fissi in ferro zincato  
Fixed feet in galvanized iron



Piedini fissi con ventose  
Fixed feet with suction glides



Ruote doppie piroettanti  
Swivelling castors



T200







### Funzionalità e design

Tavolino di scrittura ribaltabile su base singola a supporto di sedute per sale conferenze, auditorium e spazi polivalenti, caratterizzato da solidità strutturale, design essenziale e praticità di utilizzo.

### Struttura

Struttura portante e base a pavimento in lamiera d'acciaio verniciata a polveri epossipoliestere antigraffio.

### Functionality and design

Tip-up writing table on single base for conference halls, auditoriums and multi-purpose spaces, characterised by structural solidity, essential design and practical use.

### Structure

Bearing structure and floor base in steel sheet metal painted with scratchproof epoxy-polyester powder.





### Piano di lavoro

Ampio piano ribaltabile in HPL stratificato con sistema di chiusura antipánico dotato di boccole ricoperte in Teflon, che garantiscono efficienza e silenziosità nella movimentazione, e cerniera con leva d'acciaio rivestita in alluminio lucidato o verniciato.

Dimensioni: 45x28 cm (spessore 8 mm), personalizzabili su richiesta.

### Top

Wide tip-up stratified HPL top with anti-panic (movement) closure system, provided with Teflon covered bearings, which guarantee performance and silent movements, and hinge with steel lever covered with polished or painted aluminium.

Dimensions: 45 x 28 cm. (8 mm. thick), also available in custom dimensions upon request.

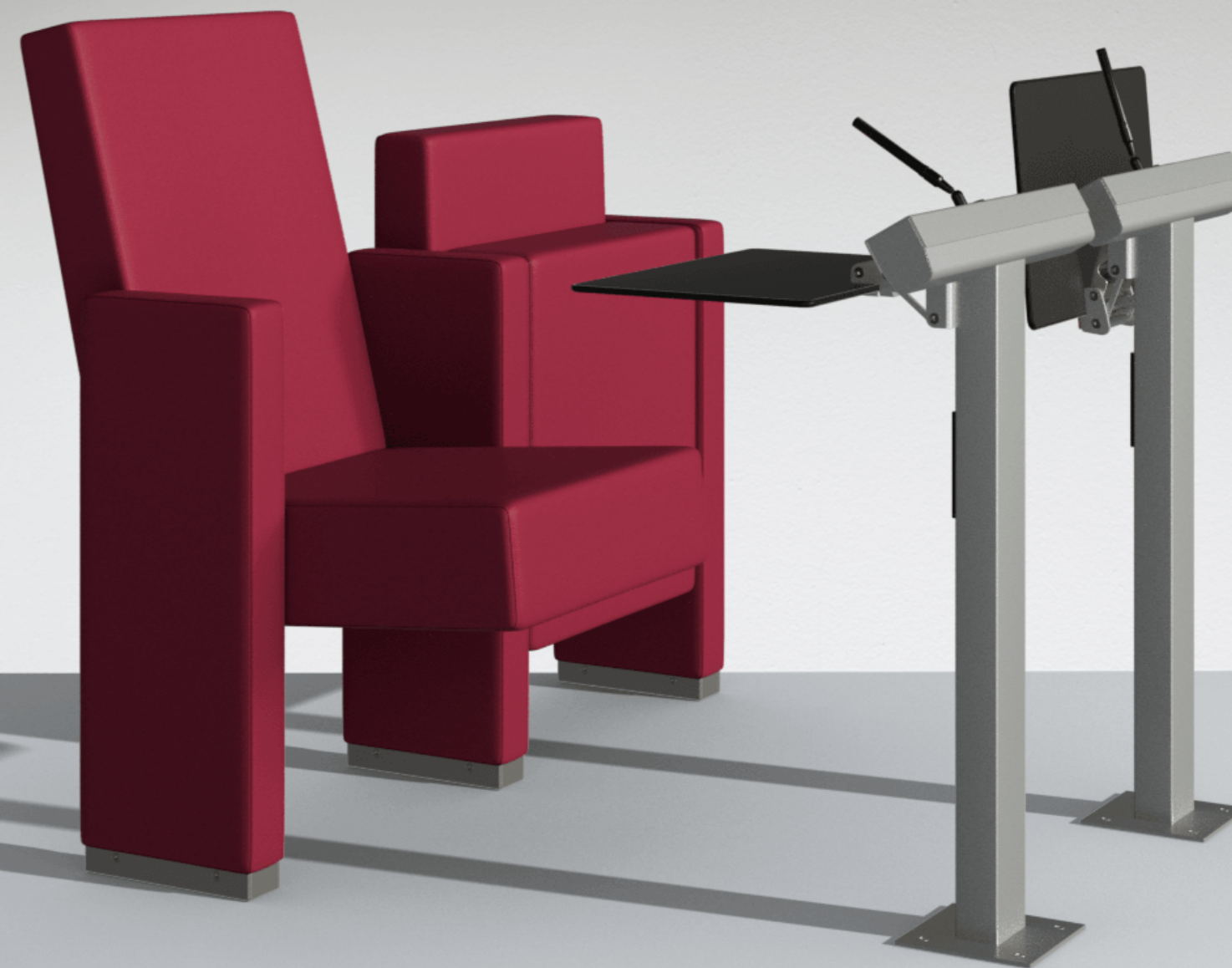



T200

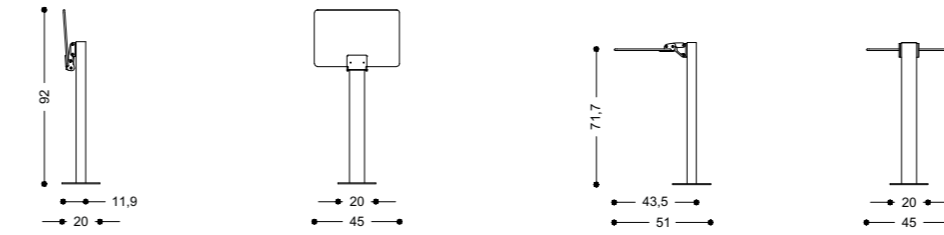

Accessori - Accessories



Predisposizione per sistema di votazione e traduzione simultanea  
Provision for voting system and simultaneous translation



Predisposizione per l'elettrificazione (presa elettrica su richiesta)  
Provision for electric power supply (socket on demand)





# Finishes



# Inca 1 Category

I colori e le finiture riportate hanno solo un valore orientativo. The colours and finishes shown have an indicative value only.



# King 1 Category

I colori e le finiture riportate hanno solo un valore orientativo. The colours and finishes shown have an indicative value only.





# Trevi 1 Category

I colori e le finiture riportate hanno solo un valore orientativo. The colours and finishes shown have an indicative value only.

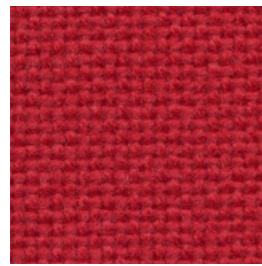

Cod. 06-022

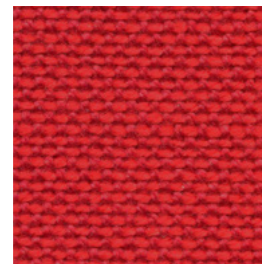

Cod. 06-017

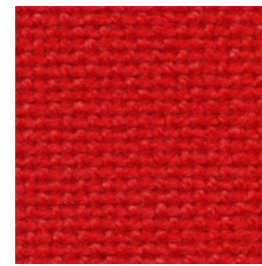

Cod. 06-014

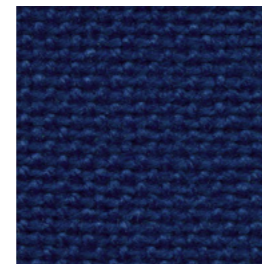

Cod. 06-086

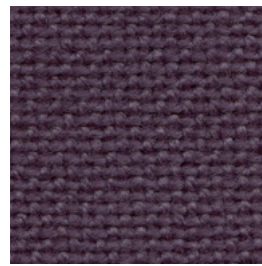

Cod. 06-035



Cod. 06-1610



Cod. 06-001

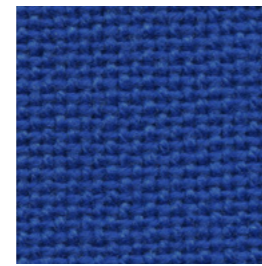

Cod. 06-041



Cod. 06-1613

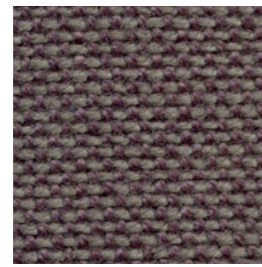

Cod. 06-094

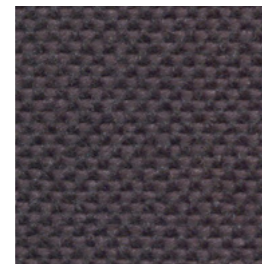

Cod. 06-058

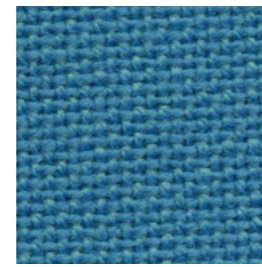

Cod. 06-009

# Maya 2 Category

I colori e le finiture riportate hanno solo un valore orientativo. The colours and finishes shown have an indicative value only.

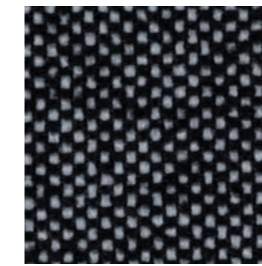

Cod. 77-9803

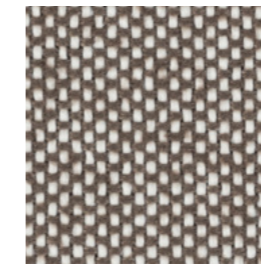

Cod. 77-9217

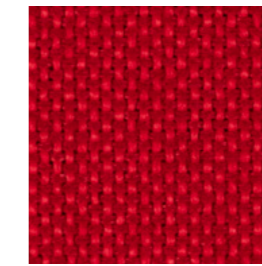

Cod. 77-9405

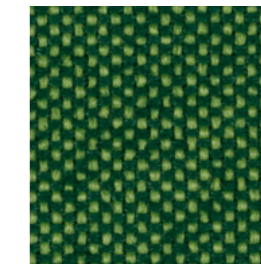

Cod. 77-9704

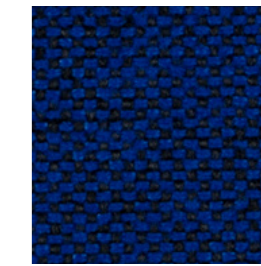

Cod. 77-9604

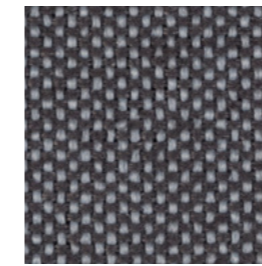

Cod. 77-9804

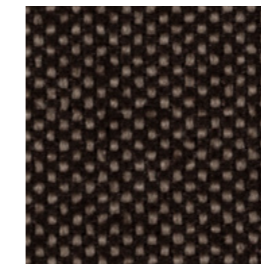

Cod. 77-9222

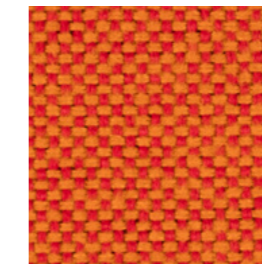

Cod. 77-9404

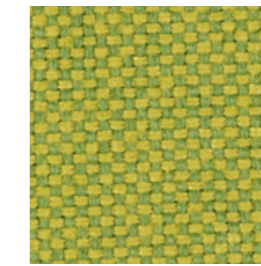

Cod. 77-9702

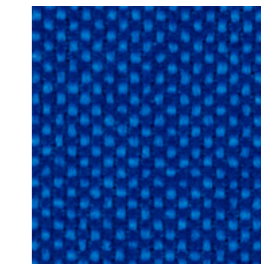

Cod. 77-9603

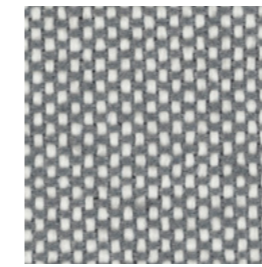

Cod. 77-9107

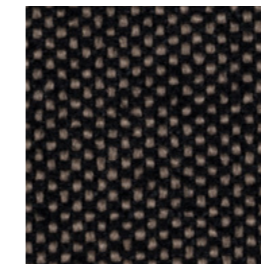

Cod. 77-9228

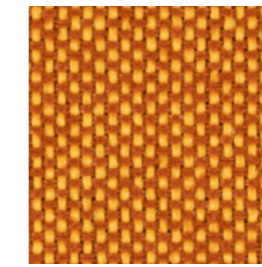

Cod. 77-9302

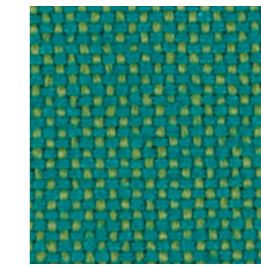

Cod. 77-9705

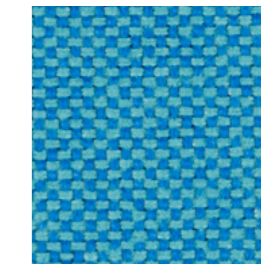

Cod. 77-9601

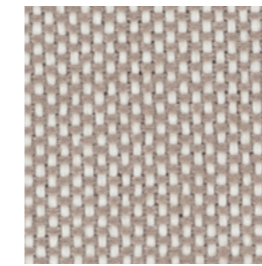

Cod. 77-9211

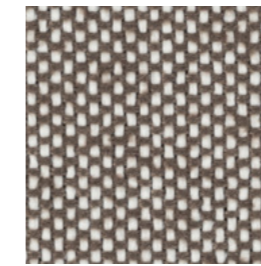

Cod. 77-9212

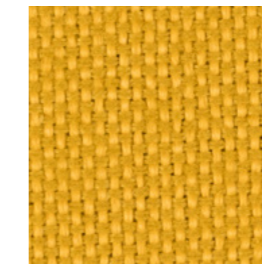

Cod. 77-9309

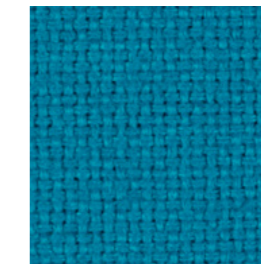

Cod. 77-6091

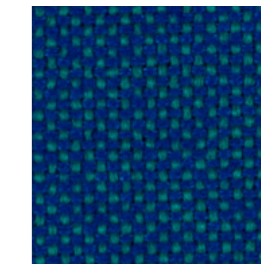

Cod. 77-9602



Silvertex 2<sup>Category</sup>

I colori e le finiture riportate hanno solo un valore orientativo. The colours and finishes shown have an indicative value only.



Extrema Au 2<sup>Category</sup>

I colori e le finiture riportate hanno solo un valore orientativo. The colours and finishes shown have an indicative value only.





I colori e le finiture riportate hanno solo un valore orientativo. The colours and finishes shown have an indicative value only.



Cod. 95-099



Cod. 95-023

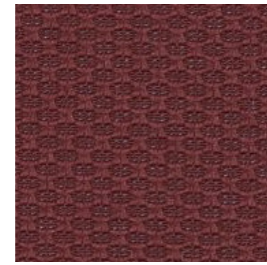

Cod. 95-013

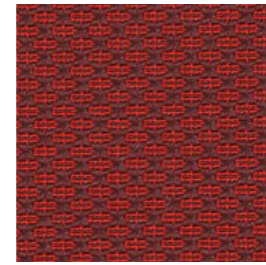

Cod. 95-012



Cod. 95-095

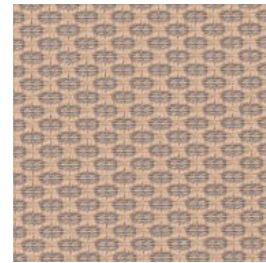

Cod. 95-073

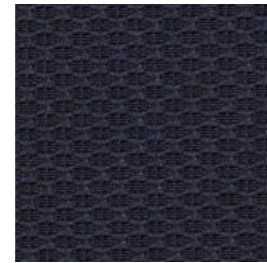

Cod. 95-055

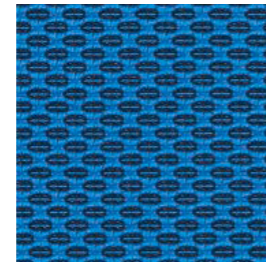

Cod. 95-051



Cod. 95-093



Cod. 95-072

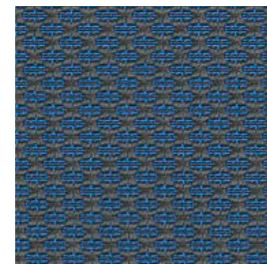

Cod. 95-053



Cod. 95-054

I colori e le finiture riportate hanno solo un valore orientativo. The colours and finishes shown have an indicative value only.

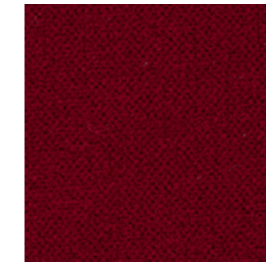

Cod. 32-021

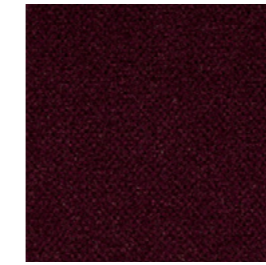

Cod. 32-037



Cod. 32-1713



Cod. 32-031

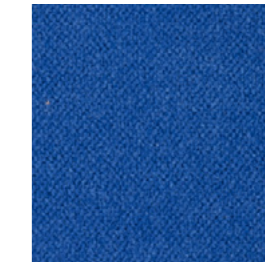

Cod. 32-009

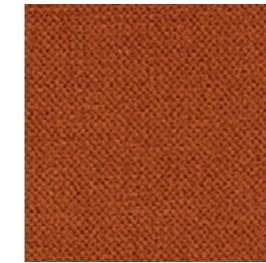

Cod. 32-030

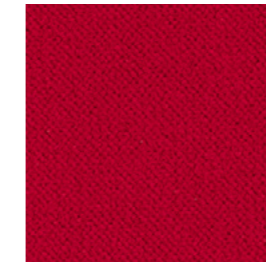

Cod. 32-014



Cod. 32-070



Cod. 32-1711



Cod. 32-003

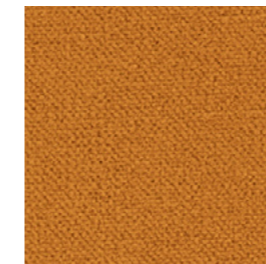

Cod. 32-017

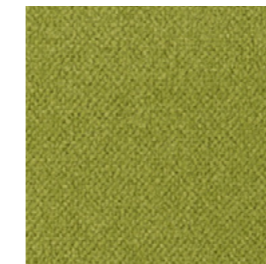

Cod. 32-011



Cod. 32-013



Cod. 32-1717

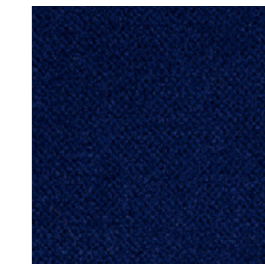

Cod. 32-038



Cod. 32-9000

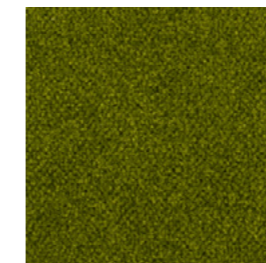

Cod. 32-007



Cod. 32-006

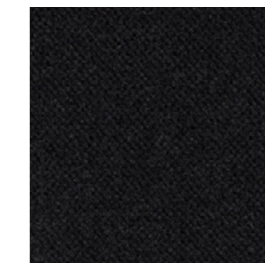

Cod. 32-018

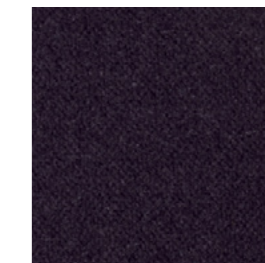

Cod. 32-024



Revive 1 <sup>3</sup>Category **kvadrat**

I colori e le finiture riportate hanno solo un valore orientativo. The colours and finishes shown have an indicative value only.

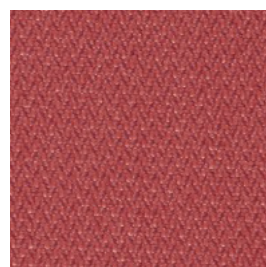

Cod. 78-664

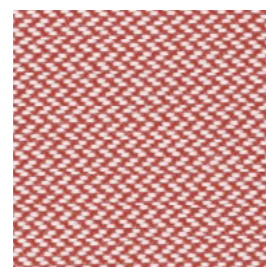

Cod. 78-524

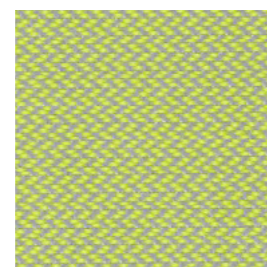

Cod. 78-914

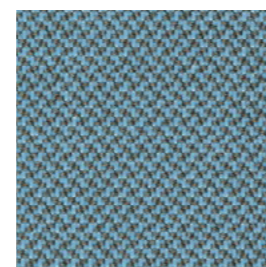

Cod. 78-834



Cod. 78-284



Cod. 78-634



Cod. 78-224



Cod. 78-454

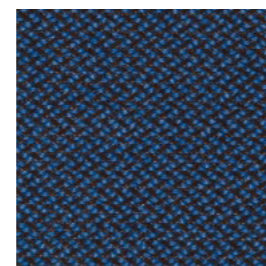

Cod. 78-774

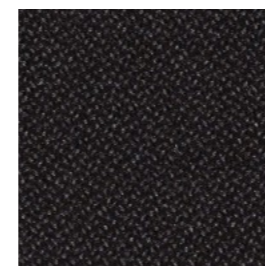

Cod. 78-194



Cod. 78-424



Cod. 78-324



Cod. 78-144

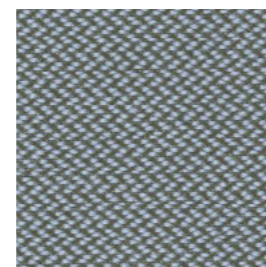

Cod. 78-944



Cod. 78-974

Remix 2 <sup>3</sup>Category **kvadrat**

I colori e le finiture riportate hanno solo un valore orientativo. The colours and finishes shown have an indicative value only.

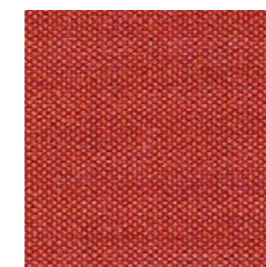

Cod. 50-014

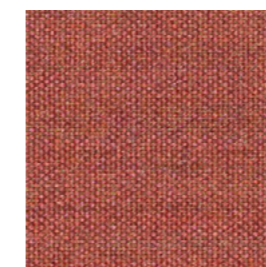

Cod. 50-065



Cod. 50-006



Cod. 50-002

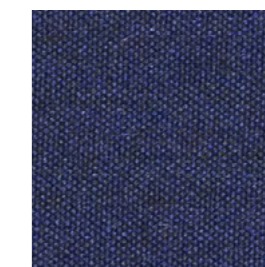

Cod. 50-003

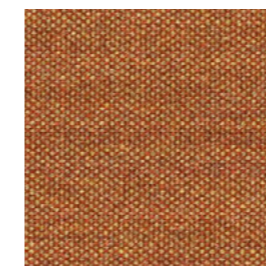

Cod. 50-043



Cod. 50-042



Cod. 50-036

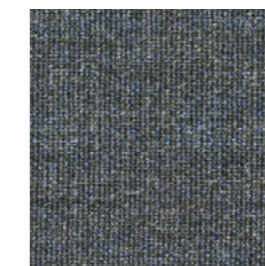

Cod. 50-075



Cod. 50-073



Cod. 50-022

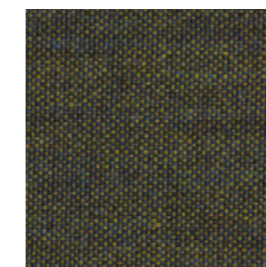

Cod. 50-084



Cod. 50-046

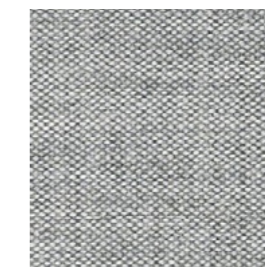

Cod. 50-025

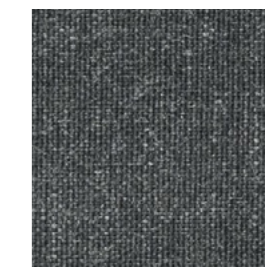

Cod. 50-017



Steelcut Trio 3 <sup>4</sup>Category **kvadrat**

I colori e le finiture riportate hanno solo un valore orientativo. The colours and finishes shown have an indicative value only.

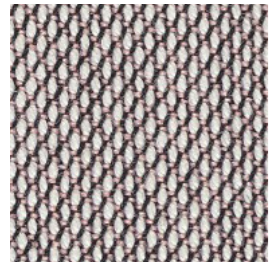

Cod. 59-616

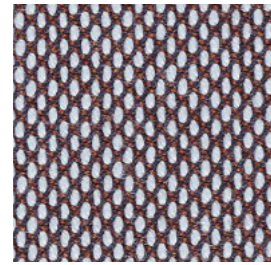

Cod. 59-336

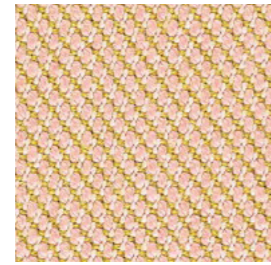

Cod. 59-506

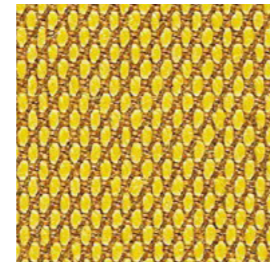

Cod. 59-453

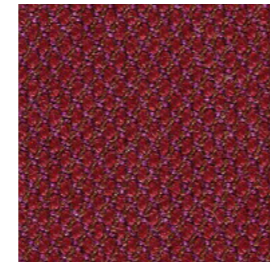

Cod. 59-686



Cod. 59-195

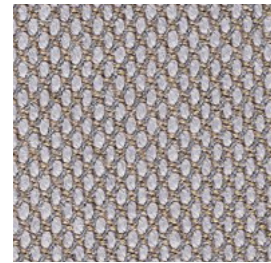

Cod. 59-246

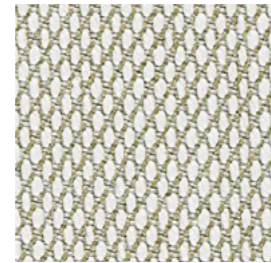

Cod. 59-213

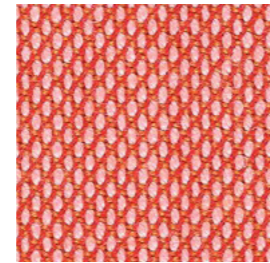

Cod. 59-526

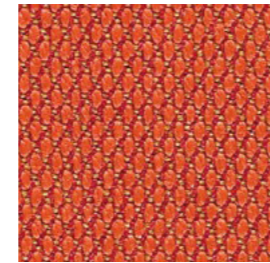

Cod. 59-533



Cod. 59-383

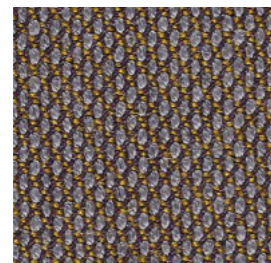

Cod. 59-376

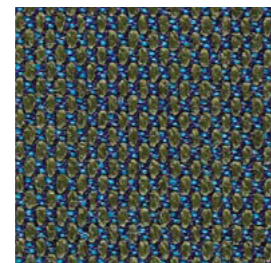

Cod. 59-883



Cod. 59-124

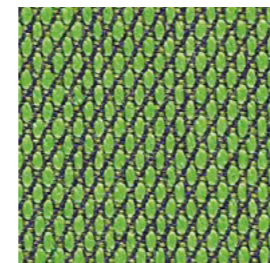

Cod. 59-953

Pelle / Leather <sup>4</sup>Category

I colori e le finiture riportate hanno solo un valore orientativo. The colours and finishes shown have an indicative value only.



Cod. 07-042

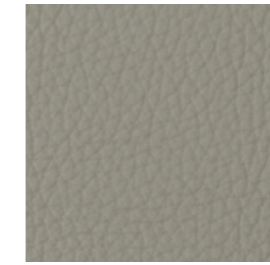

Cod. 07-012



Cod. 07-025



Cod. 07-001



Cod. 07-017



Cod. 07-023

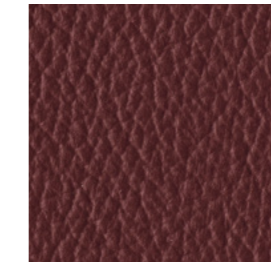

Cod. 07-037



Cod. 07-003

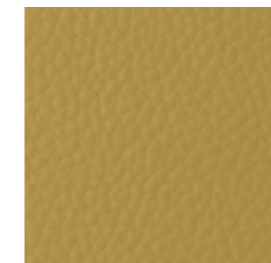

Cod. 07-009



Cod. 07-016



Cod. 07-006



Cod. 07-010

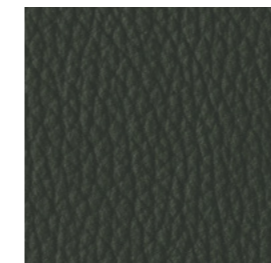

Cod. 07-089



Cod. 07-060

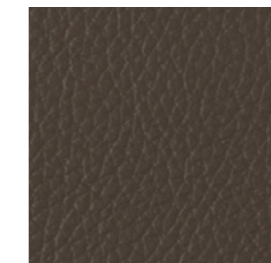

Cod. 07-011



Cod. 07-008



## Legno verniciato / Painted wood

I colori e le finiture riportate hanno solo un valore orientativo. The colours and finishes shown have an indicative value only.



Faggio  
Beech



Rovere  
Oak

## Legno massello verniciato / Painted solid wood



Faggio  
Beech

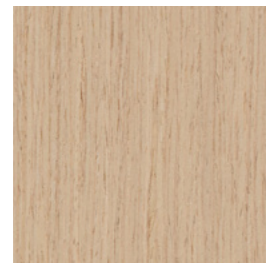

Rovere  
Oak

## Laminato HPL / HPL laminates

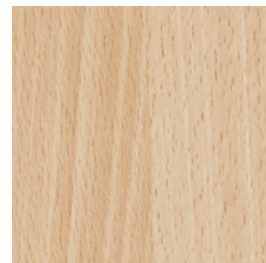

272

Faggio  
Beech

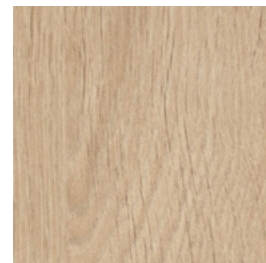

Rovere  
Oak

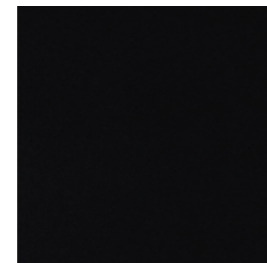

Nero  
Black

## Vernici / Paints

I colori e le finiture riportate hanno solo un valore orientativo. The colours and finishes shown have an indicative value only.



Nero  
Black

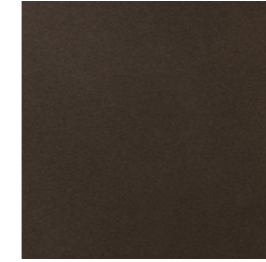

Bronzo  
Bronze



Grafite  
Graphite



Argento  
Silver

## HPL stratificato / Stratified HPL

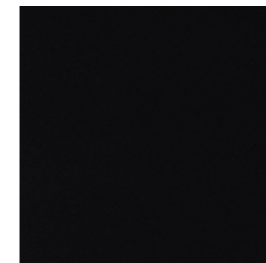

Nero  
Black

## Poliuretano integrale / Integral polyurethane

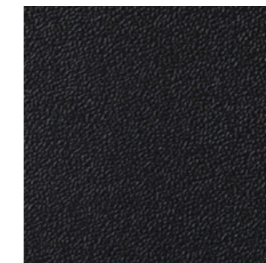

Nero  
Black

## Termoplastica / Thermoplastic



Nero  
Black

## Ferro zincato / Galvanized iron



Ferro zincato  
Galvanized iron

## Alluminio lucidato / Polished aluminium



Alluminio lucidato  
Polished aluminium



## Main references

|   |  |  |  |  |   |   |   |
|---|--|--|--|--|---|---|---|
| <p>ANGOLA</p> <p>Palace of Justice Auditorium, Luanda</p>   | <p>CHAD</p> <p>Onrtv</p>   | <p>Multimedia Center “La Passerelle”, Vitrolles</p> <p>Chamber of Commerce and Industry, Albi</p> <p>The Institut Mines-Télécom, Paris</p> | <p>Albeda College, Schiedham</p> <p>Utrecht High School</p> <p>The Atrium Convention Center Amsterdam</p>      | <p>NABA, Milano</p> <p>Istituto Europeo di Design, Milano</p> <p>Teatro Camploy, Verona</p>  | <p>Ministry of Education</p> <p>Sheikh Jaber Al Ahmad Cultural Centre</p> <p>Alshaya Burj</p>   | <p>Qatar University, Doha</p> <p>ACRPS, Doha</p> <p>Supreme Education Council, Doha</p>                           | <p>SSH Hotel School, Lausanne</p> <p>Geneva Airport</p> <p>Ecole de la Source, Lausanne</p>                                 |
| <p>ARGENTINA</p> <p>Siderca - Tenaris Group</p>   | <p>CYPRUS</p> <p>Intercollege of Nicosia</p> <p>European University</p>  | <p>IUT Paris Descartes, Paris</p> <p>Neurocampus, Bordeaux</p> <p>UPMC - Jussieu campus, Paris</p>   | <p>University of Amsterdam</p> <p>International School, Hilversum</p> <p>Medisch Spectrum Twente, Enschede</p> | <p>Fondazione La Biennale di Venezia</p> <p>Università Ca' Foscari, Venezia</p> <p>Fondaz. Università di Mantova, Mantova</p>        | <p>KIMS - Kuwait Institute for Medical Specialization</p>   |   |   |
| <p>AUSTRALIA</p> <p>University of Tasmania</p> <p>University of Queensland</p>  | <p>CROATIA</p> <p>Split University</p> <p>University of Zagreb</p>   | <p>ESC, School of Business, Rennes</p> <p>ISC Paris School of Management, Paris</p> <p>Centre de Formation de l’Intérieur, Lognes</p>      | <p>Vrije Universiteit - VU Amsterdam</p>   | <p>Auditorium San Vincenzo, Piacenza</p> <p>Teatro Padiglione Palacassa, Parma</p> <p>Università degli Studi, Parma</p>              | <p>LEBANON</p> <p>American University of Beirut</p>   | <p>RUSSIA</p> <p>Mirage Cinema, St. Petersburg</p> <p>Under Theatre, Vaganova</p>                                 | <p>TAIWAN</p> <p>Jut Group Lecture Hall, Taipei</p>   |
| <p>Flinders University, Adelaide</p> <p>Adelaide Crows Football Club</p> <p>TAFE SA Regency Campus</p> <p>324 SKR Melbourne</p> | <p>CZECH REPUBLIC</p> <p>University Campus Bohunice, Brno</p> <p>MZLU Masaryk University, Brno</p> <p>Skoda University</p>   | <p>Ogec Institut De La Tour, Paris</p> <p>Pole Universitaire, Perpignan</p> <p>Université de Montpellier, Campus Triolet</p>               | <p>HONG KONG</p> <p>Credit Suisse, Hong Kong</p> <p>France Telecom, Hong Kong</p>                              | <p>Università degli Studi, Ferrara</p> <p>Università di Bologna, Bologna</p> <p>Cefla, Imola (BO)</p>                                | <p>Deloitte Headquarters Auditorium, Gasperich</p> <p>La Maison du Savoir, Esch-sur-Alzette</p> <p>BIL Banque International de Luxembourg</p> | <p>Tyumen State University</p> <p>Saint Petersburg State University</p> <p>Theatre Music Hall, St. Petersburg</p> | <p>TURKEY</p> <p>Panora Shopping Center, Ankara</p> <p>Technical University, Istanbul</p>                                   |
| <p>AUSTRIA</p> <p>Montan University, Leoben</p> <p>Heiligenkreuz Abbey Auditorium</p>   | <p>DENMARK</p> <p>Aarhus University</p> <p>DTU University</p>  | <p>Médiathèque Chateau de la Motte</p> <p>IFSI Marseille</p> <p>Institut de l’Audition, Paris</p>  | <p>Jockey Club Betting Hall Theatre, Hong Kong</p>   | <p>Università degli Studi, Firenze</p> <p>Sala dei Duecento - Palazzo Vecchio, Firenze</p> <p>Università degli Studi, Siena</p>      | <p>Banque de Luxembourg</p>   | <p>Evolution Tower, Moscow</p> <p>TMK Group, Moscow</p>   | <p>UNITED KINGDOM</p> <p>Brunell University, London</p> <p>HSBC UK Headquarters, Birmingham</p>                             |
| <p>BAHRAIN</p> <p>Bahrain National Theatre</p> <p>Royal Police Cadet College</p>  | <p>Foss Innovation Centre</p> <p>Fredericia Theatre</p> <p>Brightpoint, Aabenraa</p> <p>UCC Campus Carlsberg, Copenhagen</p> | <p>Conseil National Des Barreaux, Paris</p> <p>École normale supérieure Paris-Saclay</p> <p>Toulouse School of Economics, Toulouse</p>     | <p>HUNGARY</p> <p>Corvinus University</p>  | <p>Camera di Commercio di Prato</p> <p>F.I.G.C., Perugia</p> <p>Università degli Studi di Perugia</p>                                | <p>MACEDONIA</p> <p>Macedonian Opera and Ballet, Skopje</p>   | <p>SAUDI ARABIA</p> <p>Damman University</p> <p>Prince Sultan University</p>                                      | <p>UNITED ARAB EMIRATES</p> <p>Al Zorah Pavilion, Ajman</p> <p>Tenaris Dubai</p>  |
| <p>BELGIUM</p> <p>American University Brussels Center</p> <p>ULB University, Brussels</p>                                       | <p>ESTONIA</p> <p>Vanemuine Tartu Theatre, Tallin</p> <p>Tartu Jakobi 2 University</p>                                       | <p>Université de Montpellier, Campus Triolet</p> <p>Conseil National Des Barreaux, Paris</p> <p>Médiathèque Chateau de la Motte</p>        | <p>ICELAND</p> <p>Aurora Observatory</p>   | <p>Università degli Studi La Sapienza, Roma Nazioni</p> <p>Unite, Sede di Roma, Roma</p> <p>Astaldi Spa, Roma</p>                    | <p>MALTA</p> <p>Golden Mile Business Center - St.Julians</p> <p>University of Malta</p>   | <p>Prince Sultan University</p> <p>KFU - King Faisal University</p>   | <p>UNITED ARAB EMIRATES</p> <p>Al Zorah Pavilion, Ajman</p> <p>Tenaris Dubai</p>  |
| <p>Hasselt-Syntra Campus, Limburg</p> <p>European Commission - Reg. Committee</p> <p>St. Rembert Hospital Torhout</p>           | <p>FRANCE</p> <p>L’Oréal, Paris</p> <p>CRAV Auditorium, Strasbourg</p>   | <p>École normale supérieure Paris-Saclay</p> <p>Toulouse School of Economics, Toulouse</p>   | <p>IRELAND</p> <p>Trinity College</p> <p>Richmond Education and Event Centre, Dublin</p>                       | <p>Università degli Studi di Perugia</p> <p>Università degli Studi La Sapienza, Roma Nazioni</p> <p>Unite, Sede di Roma, Roma</p>    | <p>MOROCCO</p> <p>IAM Conference Hall</p> <p>Ministry of Justice, Rabat</p>   | <p>SINGAPORE</p> <p>National University of Singapore</p> <p>ITE Lecture Theatres</p>                              | <p>Dubai Airport Freezone Authority Dubai</p> <p>Clemenceau Medical Center, Dubai</p> <p>American University of Sharjah</p> |
| <p>EVS Broadcast Equipment Office</p> <p>Saint-Louis Institute, Namur</p>   | <p>GERMANY</p> <p>Merseburg University</p> <p>Mallinckrodt Gymnasium, Dortmund</p>   | <p>Université de Montpellier, Campus Triolet</p> <p>Conseil National Des Barreaux, Paris</p> <p>Médiathèque Chateau de la Motte</p>        | <p>ISRAEL</p> <p>Delta Galil Auditorium</p>  | <p>Campus bio-medico, Trigatoria (Roma)</p> <p>Bnl Gruppo Paribas, Roma</p> <p>CNA, Roma</p>   | <p>NORWAY</p> <p>Melhus Cinema</p>  | <p>NTU Lecture Theatres, Nanyang</p> <p>Singapore University of Technology</p> <p>Temasek Polytechnic</p>         | <p>EDGE Group, Dubai</p>  |
| <p>BRAZIL</p> <p>Bank of Boston, San Paolo</p> <p>Santa Cruz Theatre, San Paolo</p>   | <p>GREECE</p> <p>Agemar Headquarters Auditorium, Athens</p> <p>Hertz Amphitheatre</p>  | <p>Université de Montpellier, Campus Triolet</p> <p>Conseil National Des Barreaux, Paris</p> <p>Médiathèque Chateau de la Motte</p>        | <p>ITALY</p> <p>Comune di Courmayeur, Aosta</p> <p>Università degli Studi di Torino, Torino</p>                | <p>Apple iOS Developer Academy, Napoli</p> <p>Università degli Studi di Napoli Federico II</p> <p>Università del Salento, Lecce</p>  | <p>POLAND</p> <p>Medical University of Silesia</p> <p>Krakov Theatre School</p>   | <p>SOUTH AFRICA</p> <p>Sasol Head Office, Johannesburg</p>  | <p>USA</p> <p>De Paul University, Chicago Illinois</p> <p>University of Missouri Bryant Hall</p>                            |
| <p>CANADA</p> <p>Progress Energy Canada Ltd</p> <p>Springdale Library</p>   | <p>HUNGARY</p> <p>Corvinus University</p>  | <p>Université de Montpellier, Campus Triolet</p> <p>Conseil National Des Barreaux, Paris</p> <p>Médiathèque Chateau de la Motte</p>        | <p>GERMANY</p> <p>Merseburg University</p> <p>Mallinckrodt Gymnasium, Dortmund</p>                             | <p>Villa Serena, Città Sant’Angelo (PE)</p> <p>Università di Studi Umanistici, Cagliari</p> <p>Teatro “Mauro Ganeri”, Paola (CS)</p> | <p>SPAIN</p> <p>Hotel Barcelò, Malaga</p> <p>Matarò Hospital, Barcelona</p>   | <p>URUGUAY</p> <p>Celebra Building, Montevideo</p>  | <p>University of Vermont Aiken Hall</p> <p>Commonwealth</p>   |
|   | <p>GUINEA</p> <p>National Hospital of Donka, Conakry</p>   | <p>Université de Montpellier, Campus Triolet</p> <p>Conseil National Des Barreaux, Paris</p> <p>Médiathèque Chateau de la Motte</p>        | <p>IRELAND</p> <p>Trinity College</p> <p>Richmond Education and Event Centre, Dublin</p>                       | <p>Humanitas University</p> <p>Museo M9 - Fondazione di Venezia</p> <p>Teatro Romualdo Marengo, Novi Ligure</p>                      | <p>PORTUGAL</p> <p>Aveirense Theatre, Aveiro</p> <p>Evora University</p>  | <p>USA</p> <p>De Paul University, Chicago Illinois</p> <p>University of Missouri Bryant Hall</p>                  | <p>University of Kentucky College of Medicine</p> <p>University of Vermont Aiken Hall</p>                                   |
|   | <p>HOLLAND</p> <p>University of Groningen</p>  | <p>Université de Montpellier, Campus Triolet</p> <p>Conseil National Des Barreaux, Paris</p> <p>Médiathèque Chateau de la Motte</p>        | <p>ISRAEL</p> <p>Delta Galil Auditorium</p>  | <p>MANN - Museo Archeologico Nazionale di Napoli</p> <p>Bocconi Urban Campus, Milano</p>   | <p>QATAR</p> <p>Doha Bank</p> <p>Qatar Foundation</p>   | <p>SWITZERLAND</p> <p>Aubépine College, Geneva</p>  | <p>NYU, Washington DC</p>   |



**2015**

"Best of Competition"  
Educational Spaces Innovation Awards  
2015, New Orleans, U.S.A.  
ST12. Orlandini Design  
Study benches system

**2014**

"Next Product" categoria "The most promising products"  
Office Next Moscow  
Genya. Design Dante Bonuccelli  
Conference armchairs

**2011**

"Menzione d'Onore"  
XXII Premio Compasso d'Oro  
ADI 2011  
Genya. Design Dante Bonuccelli  
Conference armchairs

**2010**

"Good Design 2010" International  
Awards by the Chicago Athenaeum  
Museum of Architecture and Design,  
Chicago U.S.A.

HL3. Design Lucci e Orlandini  
Multi-purpose seats

"Silver Awards" The best of NeoCon 2010,  
Chicago U.S.A.  
HL3. Design Lucci e Orlandini  
Multi-purpose seats

Selezione Compasso d'Oro ADI  
Design Index 2010  
Turner. Progetto del Politecnico di Milano  
in collaborazione con il centro studi  
LAMM.  
Study benches system

**2009**

Selezione Compasso d'Oro ADI  
Design Index 2009  
Genya. Design Dante Bonuccelli  
Conference armchairs

"Good Design 2009" International Award  
cat. "Furniture"  
by the Chicago Athenaeum Museum  
of Architecture and Design, Chicago

U.S.A.  
Elitra. Design Lucci e Orlandini  
Office armchairs

"Innovation Award" cat. Educational  
Solutions  
"The best of NeoCon 2009", Chicago U.S.A.  
Genya. Design Dante Bonuccelli  
Conference armchairs

"Silver Award" cat. Educational Solutions  
"The best of NeoCon 2009", Chicago U.S.A.  
Turner. Progetto del Politecnico di Milano  
in collaborazione con il centro studi  
LAMM.  
Study benches system

**2006**

"Silver Award" cat. Educational Solutions  
"The best of NeoCon 2006", Chicago U.S.A.  
Runner. Design Lucci e Orlandini  
Study benches system

Selezione Compasso d'Oro ADI  
Design Index 2006

Tulip. Bartoli Design  
Conference armchairs

**2005**

"Grand Design 2005"  
International Award, Milano  
Blade. Design Dante Bonuccelli  
Study benches system

**2004**

"Good Design 2004" International Award  
cat. "Office and Residential furniture"  
by the Chicago Athenaeum Museum of  
Architecture and Design, Chicago U.S.A.  
Compasso. Design Lucci e Orlandini  
Multi-purpose seats

Premio "Work & Emotion" categoria  
Intelligent Space,  
Eimu 2004, Milano  
Blade. Design Dante Bonuccelli  
Study benches system

Selezione Compasso d'Oro ADI  
Design Index 2004

Blade. Design Dante Bonuccelli  
Study benches system

**2001**

Selezione Compasso d'Oro ADI 2001  
Conver. Design Lucci e Orlandini  
Visitors and meeting chairs

**1998**

Design Management Award a LAMM spa  
Grandesign 1998  
Cernobbio, Como

**1992**

IF 92 Design Award  
Industrie Forum Design Hannover  
A1000. Design Lucci e Orlandini  
Multi-purpose seats

**1991**

Selezione Compasso d'Oro ADI 1991  
Cot. Design Lucci e Orlandini  
Coat-stand

**1990**

Oscar SNAI 1990 Parigi  
V 300. Design Lucci e Orlandini  
Office armchairs

IF 90 Design Award  
Industrie Forum Design Hannover  
Clack. Design Lucci e Orlandini  
Folding chair

**1989**

XV Compasso d'Oro  
ADI 1989  
Mura. Design Gino Gamberini  
Theatre armchairs

Selezione Office Design 1989  
Orgatec/Eimu  
Tab. Design Lucci e Orlandini  
Multi-purpose and office tables

**1987**

Premio per la razionalità della seduta  
tecnologica / Functionality prize for  
technological chairs.  
Promosedia, Udine  
V 300. Design Lucci e Orlandini  
Office armchairs

Selezione Compasso d'Oro ADI 1987  
Clack. Design Lucci e Orlandini  
Folding chair

**1986**

IBI Product Design Awards 1986  
Institute of Business Designers Chicago  
Modulamm. Design Lucci e Orlandini  
Multi-purpose seats

**1982**

ROSCOE 1982  
Resources Council Product  
Design Awards New York Programme  
City. Design Lucci e Orlandini  
Multi-purpose seats